

LINEAR TECHNOLOGY

OCTOBER 2007

VOLUME XVII NUMBER 3

IN THIS ISSUE...

COVER ARTICLE

Low Dropout Regulator Can Be Directly Paralleled to Spread The Heat1
Robert Dobkin

Linear in the News...2

DESIGN FEATURES

16-Channel LED Driver Drives up to 160 White LEDs with 5000:1 PWM Dimming6
Keith Szolusha

2-Phase Synchronous Buck Controller Delivers Maximum Features in Minimum Footprint10
Eric Gu and Theo Phillips

Measure Microamps to Amps or Reduce Power Dissipation by 99%, You Decide!13
Brendan J. Whelan

Pushbutton On/Off Controller Provides μ Processor Reset Monitor and Input Supply Monitoring17
Victor Fleury

LED Driver Yields 3000:1 True Color PWM Dimming with Any Buck, Boost or Buck-Boost Topology from a Wide 3V-40V Input Range20
Xin Qi

White LED Driver and OLED Driver with Integrated Schottkys and Output Disconnect in 3mm x 2mm DFN23
Alan Wei

Light Up 12 LEDs from a Single-Cell Li-Ion Battery via Highly Integrated 3mm x 2mm Dual-LED-String Driver25
Ben Chan

Low Offset 2-Wire Bus Buffer Provides Capacitance Buffering, Stuck Bus Recovery, and Tolerates High V_{OL} 28
John Ziegler

DESIGN IDEAS

.....32-40
(complete list on page 32)

New Device Cameos41

Design Tools43

Sales Offices44

Low Dropout Regulator Can Be Directly Paralleled to Spread The Heat

by Robert Dobkin

Introduction

The 3-terminal adjustable linear regulator has been around since 1976, but since then, little has changed in its essential architecture. A 1.2V reference is boosted to generate a regulated output somewhere above a minimum 1.2V. What if, however, you throw away the voltage reference and replace it with a precision current source? The result is a giant leap forward in linear regulator capability, performance and versatility. The LT3080 is the first adjustable linear regulator to do just that. This deceptively simple architectural change allows this new regulator to be directly paralleled to spread the current load and thus spread dissipated heat among the ICs. Spreading the heat makes it possible to use linear regulators in high

output current, all-surface-mount applications where only a limited amount of heat can be dissipated in any single spot on a board—applications that previously demanded a switching regulator.

When regulators are surface mounted on a system board, conductive dissipation and air-cooling limits the amount of power that can be dissipated in each chip. With a typical board, allowing a max operating temperature of 60°C to 70°C, a linear regulator can safely dissipate approximately 1W to 2W. This number depends on the ability of the board to spread the heat and air-flow across the board. If high power requirements cause the regulator to generate more heat than the board

The LT3080 is the first adjustable linear regulator that can be directly paralleled to spread the current load and thus spread dissipated heat. This makes it possible to use linear regulators in high output current, all-surface-mount applications where only a limited amount of heat can be dissipated in any single spot on a board—applications that previously demanded a switching regulator.

continued on page 3



LT, LT, LTC, LTM, Burst Mode, OPTI-LOOP, Over-The-Top and PolyPhase are registered trademarks of Linear Technology Corporation. Adaptive Power, Bat-Track, BodeCAD, C-Load, DirectSense, Easy Drive, FilterCAD, Hot Swap, LinearView, μ Module, Micropower SwitcherCAD, Multimode Dimming, No Latency $\Delta\Sigma$, No Latency Delta-Sigma, No R_{SENSE} , Operational Filter, PanelProtect, PowerPath, PowerSOT, SmartStart, SoftSpan, Stage Shedding, SwitcherCAD, ThinSOT, True Color PWM, UltraFast and VLDO are trademarks of Linear Technology Corporation. Other product names may be trademarks of the companies that manufacture the products.

Linear in the News...

Video Stars

EDN magazine launched their new online video design ideas with Linear Technology Staff Scientist Jim Williams' video clip, "Measure Nanoamps to Ensure Accurate Computer Clocks." EDN also ran a video design idea from Applications Design Manager Mark Thoren, "Build Your Own Laboratory Precision Voltage Reference." Check them out at www.edn.com

New 3-Terminal Regulator Introduced

Linear recently introduced the LT3080, a 1.1A 3-terminal LDO that can be easily paralleled for spreading dissipated heat, and requires only a single resistor to adjust the output. The device, developed by Linear Technology cofounder and Chief Technical Officer Bob Dobkin, is a follow-on to his earlier contribution in this key product area.

According to online publication *AnalogZone*, "Reducing the set resistor down to a single component is an amazing jump in three-terminal adjustable regulators, but even bigger is the ability to take the output of the regulator down to 0 V. This opens up a wealth of applications."

The 3-terminal adjustable regulator was first introduced in 1976 with the LM317. It used two external resistors that would boost the output voltage anywhere from 1.2V up to 40V. It was specified with good line and load regulation, 3V dropout, 1.5A output current and had a well controlled current limit that was constant with temperature. This device was a big advance over the earlier regulators which were fixed and had poor current limit.

One shortcoming of the LM317, and even its higher current offspring, is the inability to adjust the output below 1.2V. New high performance digital circuits require voltages below 1.2V and there is reason to believe that these voltages will drop further.

Another problem with older regulators is the inability to parallel the devices. Paralleling allows higher output current and enables spreading the dissipated power over a larger area. This is a boon in all-surface-mount or high density systems, where localized peak temperatures are limited and their compact design precludes the use of heat sinks and extra wires.

High performance switching regulators have moved in to fill this gap, providing lower output voltages and

minimizing the heat buildup. The downside of switcher solutions is cost and complexity.

The new LT3080 solves all of these problems. The output is adjustable with a single resistor down to zero and devices can be paralleled for higher output current or to spread the heat. The input to output dropout is 1.3V when used as a 3-terminal regulator, or the collector of the power

device can be connected separate from the control circuitry to allow dropout voltages of 300mV. This allows high efficiency if auxiliary supplies are available for powering the control circuitry. The LT3080 can eliminate the need to have a switching regulator for power levels that are easily handled by a linear regulator.

The LT3080 fits well with modern circuit design. Lower operating voltages, higher currents, higher density and surface mounting all preclude standard IC regulators. The new architecture allows for a regulator that fits well with high performance circuits. The device is specified up to 40V, increasing its versatility and providing good margin for transients in automotive applications.

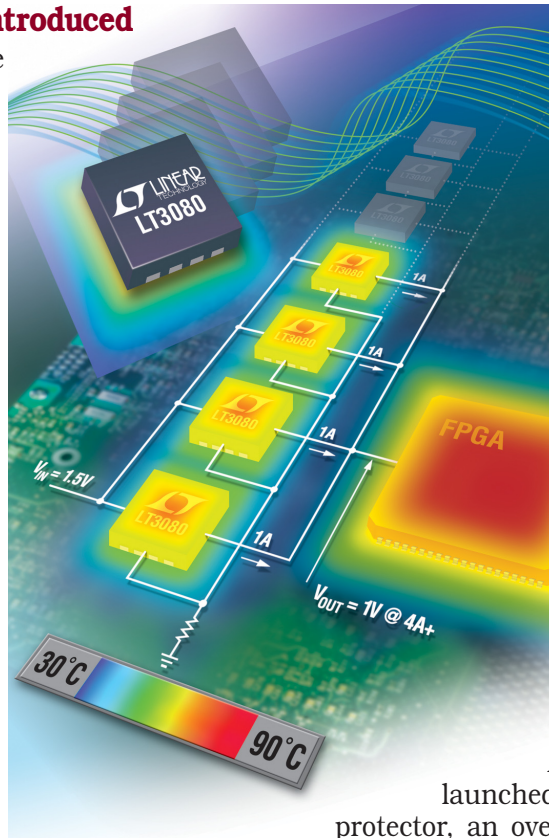

Surge Protector

Another innovative product recently launched by Linear is the LT4356 surge protector, an overvoltage protection regulator, with overcurrent protection and inrush current limiting for high availability systems. In applications where electronic systems must cope with high voltage surges of short duration, such as load dump in automobiles, the LT4356 provides solid front-end protection for valuable, safety critical downstream components. The wide input operating range of 4V to 80V enables continuous operation during cold crank conditions where the battery voltage can be as low as 4V. With its high input voltage rating, the LT4356 can handle transient voltages of 100V and higher, and provides reverse input protection to -30V without damage to itself or the load. The LT4356 lends itself well to automotive, industrial and avionics applications, as well as positive high voltage distributed power Hot Swap™ systems.

The device is a featured new product in the most recent issue of *Auto Electronics* magazine, which highlighted the product's ability to protect electronic systems from high voltage surges in automotive applications.

LT3080, continued from page 1

can dissipate, the regulator must be mounted separately on a heat sink. In all-surface-mount systems, this is not an option, so the limitation of power dissipation (1W for example) limits the output current.

Figure 1 shows the maximum output current at different input-output differentials that can be obtained for a regulator with both 1W and 2W dissipation. Paralleling LT3080s increases the maximum total output current by spreading the heat, helping to maintain low peak temperatures.

The LT3080 is also especially well suited to applications needing multiple rails. The new architecture adjusts down to zero with a single resistor, handling modern low voltage digital ICs. Adjusting to zero output makes it possible to shut off the powered circuitry when the input is preregulated—such as a 5V or 3.3V input supply. External resistors in series with IN can help spread the heat, keeping the system all surface mount.

Finally, the new regulator is made in a 40V bipolar process. This allows high input voltage as well low operating voltage, since bipolar transistors turn on at 0.6V.

Internal Precision Current Source Makes it Possible to Parallel the LT3080

A precision “zero” TC 10 μ A internal current source is connected to the non-inverting input of a power operational amplifier. The power op amp provides a low impedance buffered output from the voltage on the non-inverting input. A single resistor from the non-inverting input to ground sets the output voltage and if this resistor is set to zero, zero output results. As can be seen, any output voltage can be obtained from zero up to the maximum defined by the input power supply.

What is not so obvious from this architecture is the benefits of using a true internal current source as the reference as opposed to the bootstrapped voltage reference of older regulators. A true current source al-

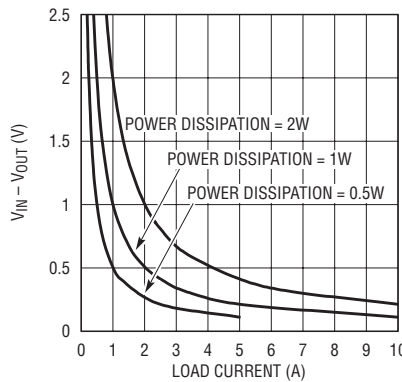

Figure 1. The available output current as a function of input-output differential and allowable power dissipation. At 2W, 1A output currents are possible even with 1V to 2V input-to-output differential.

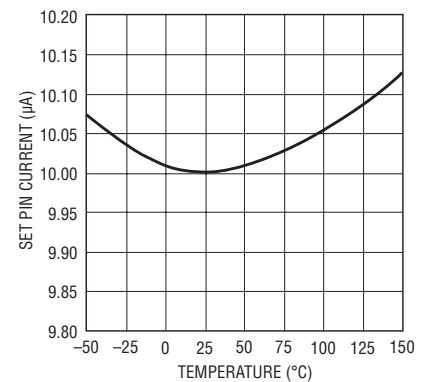

Figure 2. Temperature performance of the LT3080's precision current source.

lows the regulator to have gain and frequency response independent of the output voltage since the loop gain does not change. Traditional adjustable regulators, such as the LT1086, have a change in loop gain and bandwidth with output voltage as well as bandwidth changes when the set/adjustment pin is bypassed

to ground. With the LT3080, however, the loop gain remains unchanged with changing output voltage or bypassing. Output regulation is no longer fixed at a percentage of the output voltage but rather a fixed number of millivolts. With a true current source, all the gain in the buffer amplifier provides regulation; none of it is needed to amplify the reference to a higher output voltage. This, and the LT3080's precise DC

Table 1. Comparison of the LT3080 to traditional 1A regulators

	LT317	LT1086	LT3080
Dropout (V)	3V	1.5V	1.3V or 300mV
Min Load (mA)	10	10	0.3
Min Output (V)	1.2	1.2	0
I_{OUT} (A)	1.5	1.5	1.1
Parallel Operation	—	—	
External Resistors	2	2	1

Table 2. Some key specifications for the LT3080

Parameter	Value
Load Regulation, $I_{OUT} = 10\text{mA to } 1.1\text{A}$	<1mV
Line Regulation, $V_{IN} = 2\text{V to } 40\text{V}$	<1mV
SET Pin Current	10 μ A \pm 1%
Min Load Current	0.3mA
SET to OUTPUT Offset	1mV
Operating Temp Range	-55 $^{\circ}$ C to 125 $^{\circ}$ C
Dropout (3-Terminal) 1.1A	1.3V
Dropout (4-Terminal) 1.1A	0.3V
Ripple Rejection (120Hz)	75 dB

characteristics, makes it possible to easily parallel regulators (see below: "It is Easy to Parallel the LT3080").

High Performance

No sacrifices were made in regulator performance for the LT3080. Line and load regulation are excellent over temperature. Its low dropout and a new architecture make it extremely versatile. On chip trimming keeps the accuracy of the reference current below one percent, and the offset voltage between the SET pin and the output to under 2mV.

Line regulation is virtually immeasurable, a few nanoamps, since the internal circuitry double-regulates the current source section. The temperature performance of the reference is shown in Figure 2 and is nearly flat from -55°C to 150°C . Thermal limiting is set at about 160°C . Quiescent current is only about $300\mu\text{A}$, allowing this device to be used in light load and battery-powered applications. High frequency ripple rejection is also excellent, making the LT3080 a good fit as a post regulator to switching regulators when low output ripple is needed.

Operation of the LT3080

Figure 3 shows a block diagram of the LT3080. The simplest application, as a 3-terminal adjustable regulator, is shown in Figure 4. The V_{CONTROL} and IN pins are tied together. (These two pins can connect to different supplies for additional thermal benefits, described below.) The only added components are input and output capacitors and a resistor to set the output voltage. In this case, the output is set to 1.8V, which at 1.3V dropout works with a 3.3V input. Input and output capacitors are required for stability—they can be ceramic, tantalum, or electrolytic capacitors. Unlike older 3-terminal regulators, the minimum load current is guaranteed at only 1mA for this device. By making the adjustment resistor zero or tying the SET pin to the ground with a switch, the output goes to zero, turning off connected circuitry. Typically, the quiescent current is under $300\mu\text{A}$.

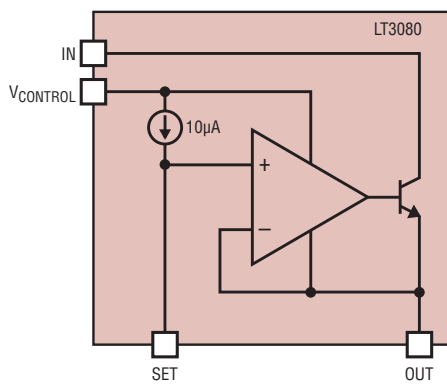

Figure 3. Block diagram of the LT3080. Four terminals are available from the package to allow the device to be used in a low dropout mode with only 300mV input-to-output dropout.

The SET pin is very high impedance and the output voltage is set by the $10\mu\text{A}$ current times an external resistor. Even a $0.1\mu\text{F}$ capacitor is large enough to bypass the SET pin at 60Hz, allowing for reduction of output noise and pickup into the SET pin.

With a capacitor on the SET pin, output noise is $40\mu\text{V}_{\text{RMS}}$ —about the

same as many low noise regulators. In other applications, the SET pin can be driven with an amplifier or a reference voltage to be used as a power buffer. With multiple regulators, the SET pins and outputs can be tied together for paralleling the regulator (described below). Grounding the SET pin brings the output to zero.

V_{CONTROL} Pin Offers Additional Ways to Spread the Heat

Clearly, one of the driving design objectives for this new regulator was to enable the thermal design for surface mount boards—notably eliminating the need for heat sinks. Paralleling LT3080s makes a significant difference, but another feature also helps. The collector of the output transistor is available at the V_{CONTROL} pin (see Figure 3). This can decrease peak temperatures in two ways.

First, the dropout on the collector is 400mV (IN pin) so it can take a lower voltage supply than is used for the LT3080's control circuitry (1.3V

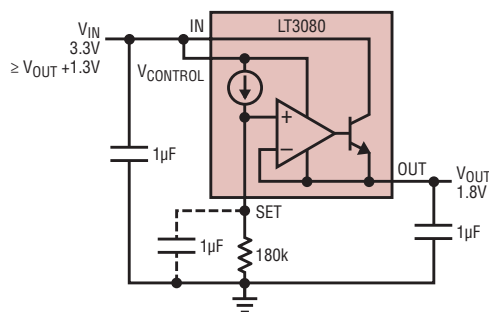

Figure 4. Basic hookup for the LT3080 regulator. The IN and V_{CONTROL} pins are tied together and a single resistor sets the output voltage. A $1\mu\text{F}$ output capacitor ensures stability. If the adjustment resistor is adjusted to zero, the output is zero.

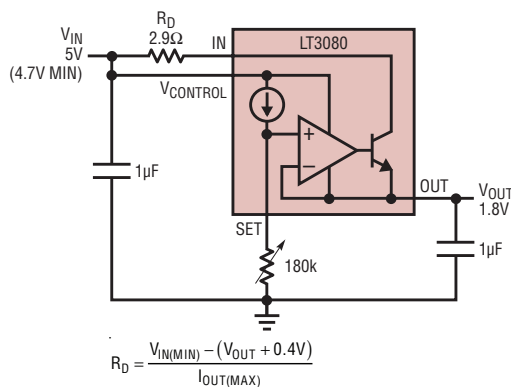

Figure 5. Adding a resistor in series with the collector of the output device to remove some of the power dissipation from the regulator. This disperses heat around the surface mount board rather concentrating it at the regulator.

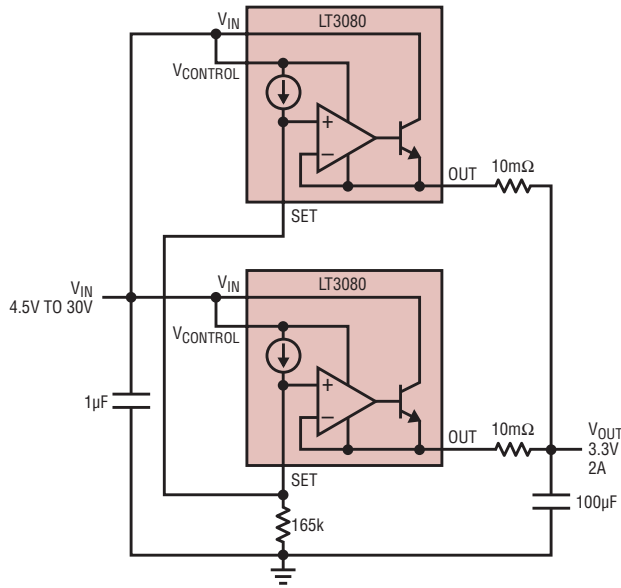

Figure 6. Paralleling of two regulators. Need more current? Add more regulators. Current sharing is assured by the 10mΩ PC board traces, which act as ballast resistors.

dropout). Lowering the input-to-output voltage on the power transistor increases efficiency and thus reduces dissipation.

Second, a resistor can be inserted in series with the collector. Adding this resistor splits power dissipation between the internal power transistor and an external resistor so that some of the heat from the IC can be moved to elsewhere on the PC board. Figure 5 shows such a design using a 2.9Ω resistor. The dropout voltage for the output transistor is only 400mV, so several volts can be dropped across the external resistor, minimizing the heating of the IC. At full load, the external resistor drops approximately 3V and dissipates 3W. To minimize peak temperatures on a PC board, this resistor can be split into several 1Ω resistors and thus further spread dissipated heat. The power dissipation in the LT3080 peaks at about 750mW when the power dissipation in the resistor and the power dissipation in the transistor are equal. The copper planes in the PC board can easily handle this power.

Of course the LT3080 can be operated in 3-terminal mode by simply connecting the $V_{CONTROL}$ pin to the power input pin, but this limits the input to the 1.3V dropout of the regulator. Alternately, by tying the IN

pin to a lower voltage than $V_{CONTROL}$, it is possible to produce a 1.1A, 2.5V to 1.8V or 1.8V to 1.2V regulator with low dissipation—likewise for other low IN – OUT differentials. To achieve the same peak operating temperatures, the dissipation constrained design current must be lower for higher IN – OUT differentials, such as 5V to 3.3V or 3.3V to 1.5V.

Table 3. Trace resistance for ballast resistors in mΩ/in

	10mil Width	20mil Width
1oz Weight	54.3	27.1
2oz Weight	27.1	13.6

It is Easy to Parallel the LT3080

The architecture of the LT3080 allows direct paralleling unlike any other type of regulator. Parallel linear regulators distribute the current load and distribute power dissipation around the system board. Need more power but can't afford more spot heating? Add more regulators. Even paralleling 5–10 devices is reasonable.

Practical current sharing by parallel LT3080s is made possible by internal trimming, which keeps the offset voltage between the adjustment pin and the output under 2mV. Figure 6 shows how easy it is to parallel LT3080s. Simply tie the SET pins of the LT3080s together, and do the same for the IN pins. This is the same whether it's in 3-terminal mode or has a separate IN supply. The outputs are also connected in common but with a small piece of PC trace in series with each OUTPUT

continued on page 27

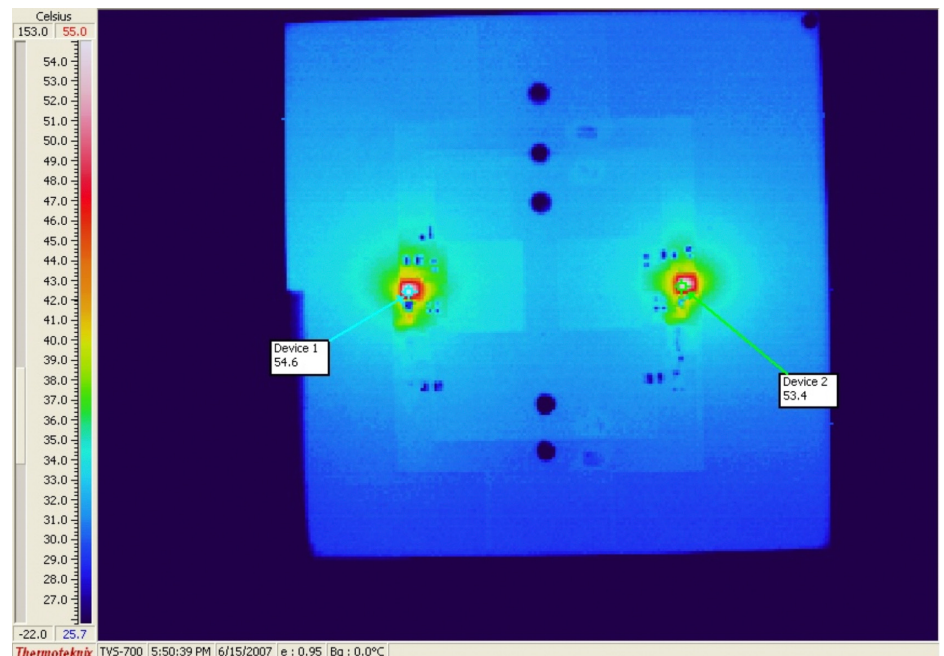

Figure 7. Thermograph shows two regulators, each dissipating 0.7W from a 0.7V input-to-output differential at 2A total load. The result is a 28°C rise over ambient at each IC on a two sided PC board.

16-Channel LED Driver Drives up to 160 White LEDs with 5000:1 PWM Dimming

by Keith Szolusha

Introduction

The light behind the large displays comes increasingly from the smallest lights: LEDs. A lot of LEDs. They light large screen LCD televisions, giant LED billboards and even stadium advertisements. In such big displays, driving hundreds of LEDs requires a large quantity of high voltage drivers that can accurately control a number of long strings of LEDs, each string with its own high PWM dimming ratios. A simple, low-component-count solution is a must, especially in consumer electronics.

The LT3595 buck mode LED driver has 16 individual channels—each driving up to 50mA from inputs up to 45V. It is possible with the LT3595 to drive 160 bright, white LEDs driven from a single converter. Each channel has a separate PWM input that is capable of up to 5000:1 PWM dimming ratio.

The LT3595 buck mode LED driver has 16 individual channels—each driving up to 50mA from inputs up to 45V. One advantage of its 56-pin QFN package is the availability of individual PWM pins for each of the 16 channels. This allows independent control over the brightness of different areas of a monitor or display. For instance, the secondary picture of a picture-in-picture display can have a different brightness than the main picture.

Each channel requires only a tiny chip inductor and an even tinier ceramic output capacitor. The only other required components are a single input capacitor and current-determining set resistor (Figure 1). All sixteen channels of catch diodes, power switches, and control logic with compensation are squeezed inside the LT3595's relatively small 56-pin, 5mm × 9mm QFN package.

The LT3595 boasts 92% peak efficiency at a 2MHz switching frequency.

5000:1 PWM Dimming

The PWM dimming capability of the LT3595 is as high as 5000:1. Figure 2 shows the 5000:1 PWM dimming waveform and a very square looking LED current waveform. Even at a mere 2μs on-time, a 20mA LED current snaps up

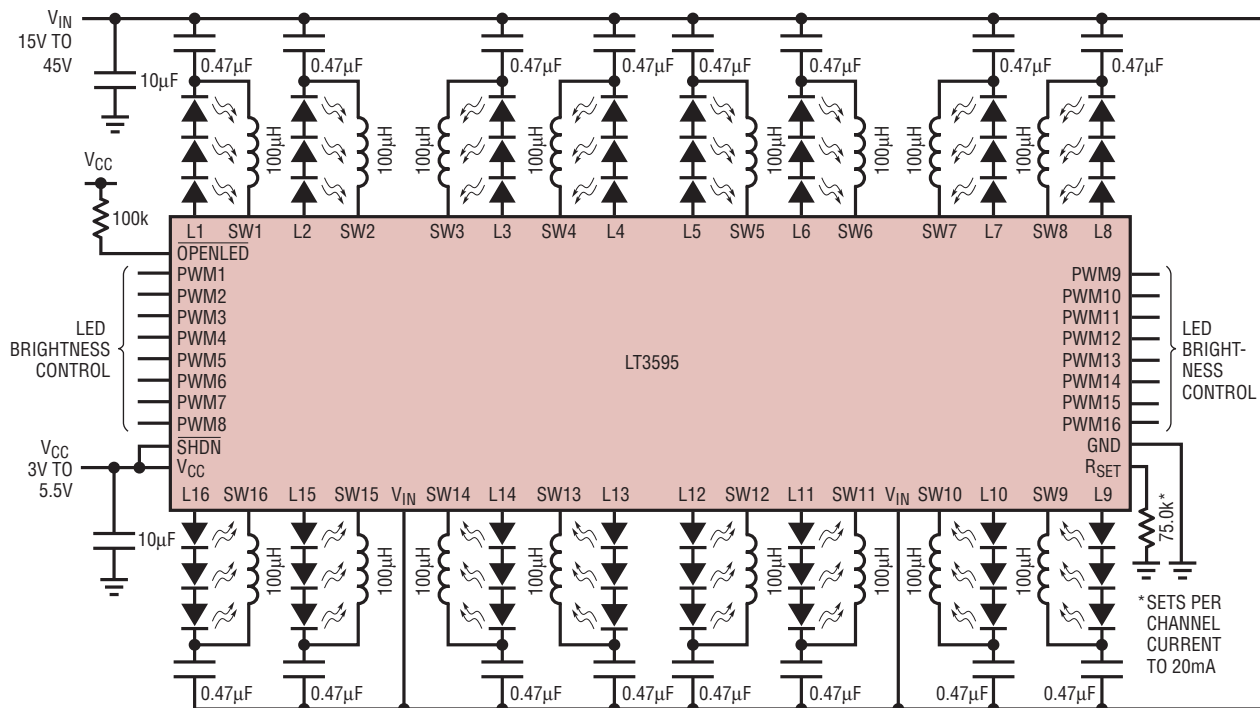

Figure 1. A 16-channel LED driver. The 15V–45V input is used to drive three white LEDs per channel with 5000:1 PWM dimming.

and turns off in sync with the 100Hz PWM signal. Higher PWM dimming ratios are achievable with lower PWM frequencies, but 100Hz guarantees that there is no visible flicker.

One advantage of a 56-pin QFN package is the availability of individual PWM pins for each of the 16 channels. In some applications, the brightness of the entire screen is uniform and all of the PWM pins can be tied together and driven from a single PWM waveform. Ideally, every point on the screen or display has the same brightness

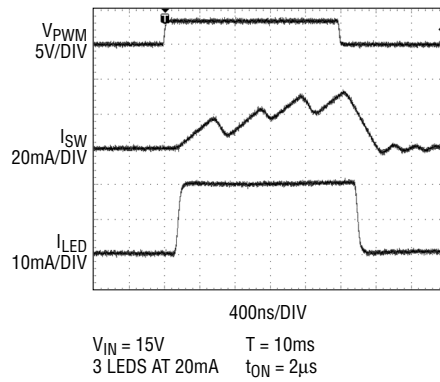

Figure 2. 5000:1 PWM dimming waveforms for the circuit in Figure 1.

determined by a single PWM setting. However, it may be a feature for some billboards or television screens with picture-in-picture to show small sections or regions of the display in higher brightness than others for forefront and background effects. In this case, it is an advantage to be able to provide some higher dimming PWM waveforms to several channels and run different brightness on other channels. PWM can also be used to completely turn off some channels or sections of a display while leaving others on. This is

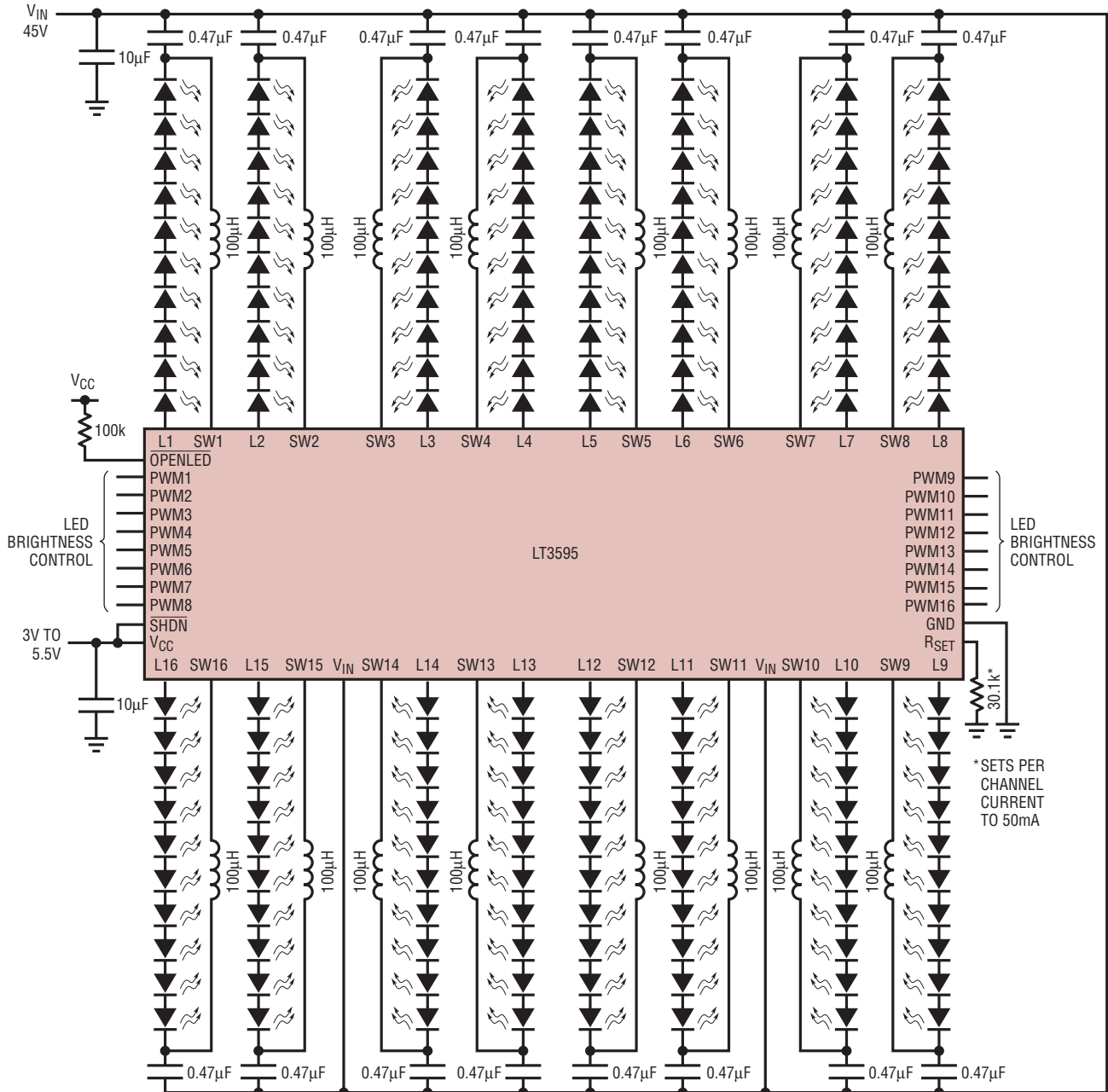

Figure 3. A 16-channel LED driver for 160 white LEDs from a 45V input. PWM dimming ratio is 5000:1.

particularly useful for individual pixel control of giant billboards and gives the designer control of an amazing 16 pixels per IC.

Adjustable 50mA LED Current per Channel

LED brightness is normally set by static current. The LT3595 can drive as high as 50mA per channel directly through a string of LEDs. A single external set resistor is all that is needed to set the LED current for all 16 channels. Each channel has the same programmed LED current—set between 10mA and 50mA. LED current accuracy is within 8% from channel-to-channel.

The fixed frequency, current mode control scheme provides stable operation over a wide range of input and output voltages and currents. Direct control of the LED current through internal sense resistors for each channel and internal switches and control circuitry for each channel provide excellent constant current source regulation for LED driving. The internal 100mA power switches and

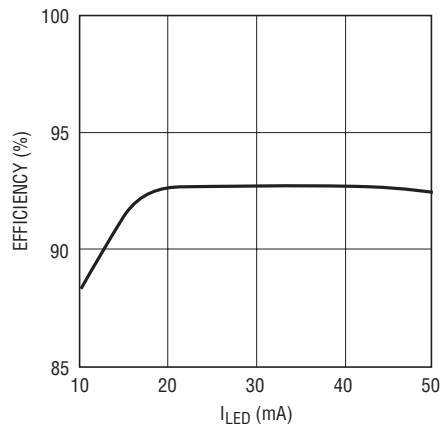

Figure 4. Efficiency of the 160-LED driver shown in Figure 3 is over 92%.

exposed thermal pad of the 56-pin QFN provide enough power and thermal management to handle the power and heat of 16 channels at 50mA.

45V Input to Any Number of LEDs

The LT3595 has a 45V maximum input voltage on its two V_{IN} pins. With an 80% maximum duty cycle at 2MHz switching frequency, this allows a fairly low dropout and up to 35V LED output

per string. On the flip side, the low minimum on-time of the IC (around 70ns) allows down to a single white LED to be run at 10mA–50mA from a 42V input.

Each channel of the LT3595 can support any number of LEDs as long as the total string voltage is between 3V to 35V. The only other requirement is that the duty cycle is below 80% and on-time is above the minimum rating. One channel can have the maximum number of LEDs and another channel can have the minimum number of LEDs. This is typical in RGB applications where each color requires a different number of LEDs, such as 8 red, 8 green, and 4 blue.

16 Fully Integrated and Independent Channels

The block diagram in Figure 5 shows the fully integrated design of the LT3595. Each channel includes a 100mA, 48V NPN power switch, Schottky diode, sense resistor, error amplifier, compensation components and other bias and control circuitry.

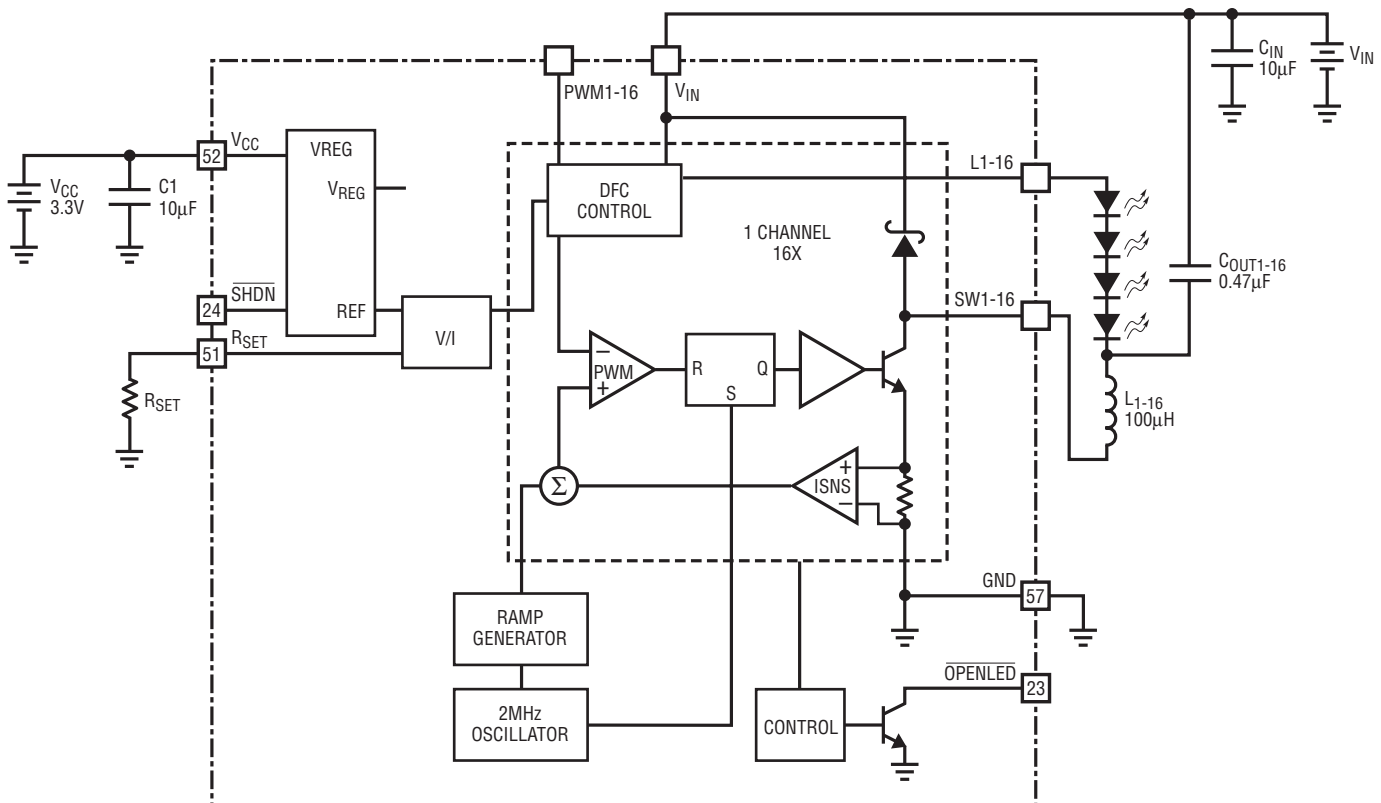

Figure 5. Block diagram for the LT3595

The 16 channels run independently, but regulate to the same LED current at the same, internally fixed switching frequency of 2MHz.

Each channel has its own PWM pin and separate dimming logic. Nevertheless, all the channels must be synchronized to the rising edge of the PWM signal, where dimming is created by varying duty cycle. Of course, the falling edges can be asynchronous.

The maximum junction temperature is rated at 125°C. The 31°C/W thermal capabilities of the 56-pin QFN can be accomplished with proper layout of the IC for excellent grounding and thermal management. Without a decent ground plane or correct connection of the thermal pad, the thermal impedance of the IC can creep up to unacceptably high levels.

Low Shutdown Current

When the shutdown pin is pulled low, all 16 channels turn off and the part consumes a quiescent current of just 15µA. Low shutdown current saves battery energy and extends its lifetime. In shutdown, the open LED comparator is disabled and not valid. If the shutdown pin is left high and the PWM pins are pulled low, the LEDs turn off, but the quiescent current remains around 280µA. The open LED pin function is still valid in this case.

Recommended Layout

The LT3595 comes in a thermally enhanced 56-pin 5mm × 9mm QFN package. This fully integrated part minimizes layout, complexity, and cost of otherwise high component count multichannel LED driver solutions. With 31°C/W thermal resistance, it is possible to run at full 50mA LED current and high number of LEDs without violating the 125°C junction temperature rating.

Layout is important for the LT3595. The ground connection is only tied to the thermal pad (pin 57). Therefore, the input capacitors, set resistors, and control logic such as PWM signals, shutdown signal and overtemperature monitor must all be tied to the com-

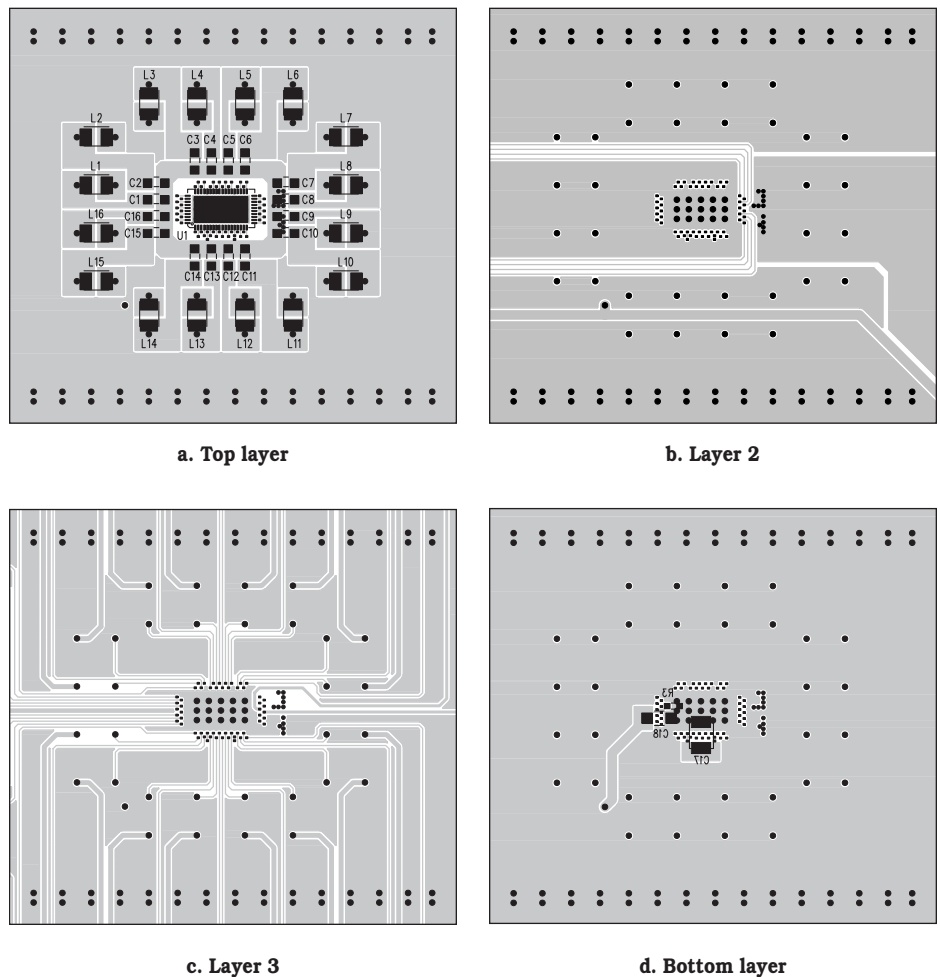



Figure 6. Suggested board layout for the LT3595

mon ground at the thermal pad. To minimize circuit noise and ripple, it is best if the input capacitors and set resistor are attached to ground on the backside of the board with the shortest connection possible between ground and their respective pins. Figure 6 shows the recommended layout. For a 5mm × 9mm 56-pin QFN package, it may be best if the traces and vias are small. The layout is optimized if vias have a drill size of 6mil (.006 inches) or less with pad of 12mil or less. Clearance between metal traces and pads should be set at 5mil or below.

Conclusion

The LT3595 is a 16-channel buck mode LED driver with 5000:1 PWM dimming. The high 45V input voltage, 50mA LED current, and 2MHz switching frequency make this a very powerful multichannel LED driver for

big screen televisions, billboards and stadium displays. The fully integrated solution in the compact 5mm × 9mm QFN package makes the designs small and simple. 5000:1 PWM dimming is one of the highest PWM dimming capabilities available in an integrated DC/DC converter LED driver IC. The inductors, the input and output capacitors, the set resistor and the LEDs are the only required external circuitry. The 16 independently controlled channels maximize the flexibility of the LT3595. 

Want to know more?
visit:
www.linear.com
or call
1-800-4-LINEAR

2-Phase Synchronous Buck Controller Delivers Maximum Features in Minimum Footprint

by Eric Gu and Theo Phillips

Introduction

The LTC3850 is a feature-rich dual channel synchronous step-down switching regulator available in a 4mm x 4mm QFN package. It is designed to meet today's high performance power application needs. With constant frequency peak current mode control for clean operation over a broad range of duty cycles, the LTC3850 is

a response to customer requests for a cost-effective solution that balances ease of use, efficiency, precision and performance.

Familiar Features, and Some New Ones

The LTC3850's two channels run out of phase, which reduces the input RMS current ripple and thus the input capacitance requirement. Switching frequency can be adjusted from 250kHz to 780kHz, either set with a voltage on the FREQ/PLLFLTR pin, or synchronized to a signal into the MODE/PLLIN pin. During high frequency operation, the LTC3850 can operate normally at low duty cycles due to its short top switch minimum on-time. For example, a 20V to 1.5V converter operating at 700kHz requires a minimum on-time of less than

$$\frac{1.5V}{(20V) \cdot (700kHz)} = 107ns$$

The LTC3850 can cycle its strong top gate drivers in just 90ns, making this low duty cycle application a reality.

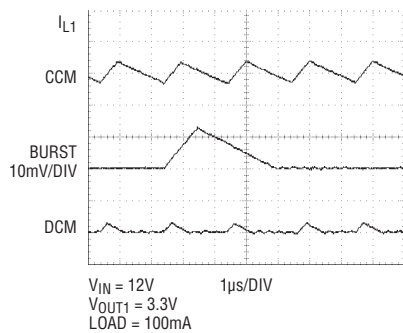

Figure 1. Three modes of operation. Continuous mode features predictable, constant frequency operation. Burst Mode® operation has the best light-load efficiency, with somewhat higher output ripple. Pulse skip mode is a compromise between the other two.

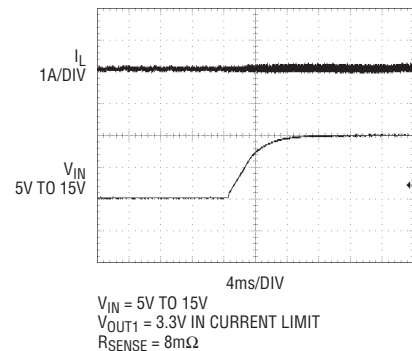

Figure 2. The LTC3850 is a peak current mode controller. As such, it uses a compensating ramp on the inductor up-slope to ensure stability at duty cycles greater than 50%. Alone, the ramp would cause current limit to drop at high duty cycles, but the LTC3850 uses a patent-pending scheme to prevent this behavior. Here, the LTC3850 is operating in current limit, and peak current is well-controlled when duty cycle swings from 66% to 22%.

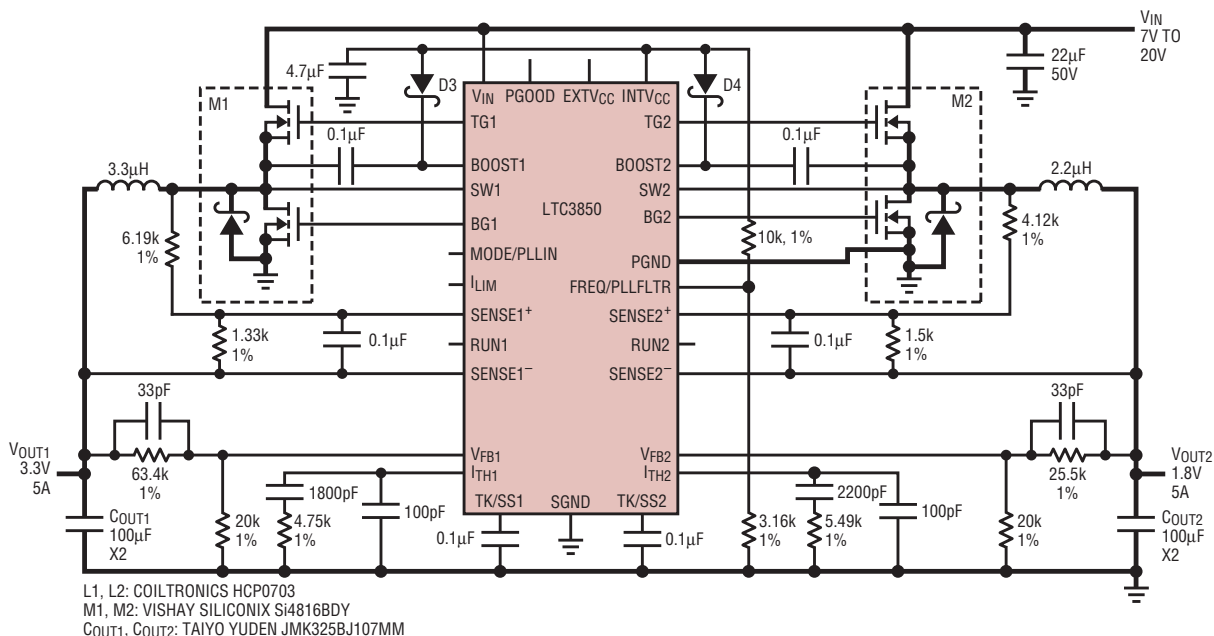

Figure 3. Schematic for a 2-channel, 5A/500kHz regulator with DCR sensing.

At heavy loads, the LTC3850 operates in constant frequency PWM mode. At light loads, it can switch in any of three modes (Figure 1). Burst Mode operation switches in pulse trains of one to several cycles, with the output capacitors supplying energy during intervening sleep periods. This provides the highest possible light load efficiency. Forced continuous mode offers PWM operation from no load to full load, providing the lowest possible output voltage ripple. Pulse skipping mode operates at a constant frequency, but always turns off the synchronous switch before inductor current is allowed to reverse. This method reduces

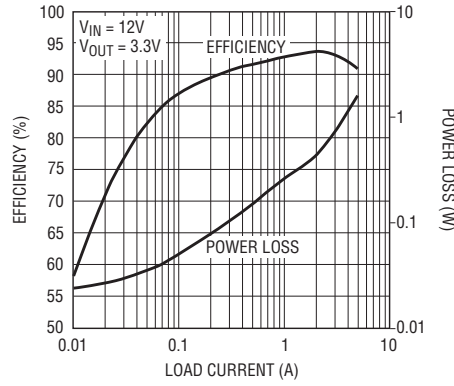

Figure 4. Efficiency and power loss for Figure 3, Channel 1.

light load ripple compared to Burst Mode operation and improves light

load efficiency compared to forced continuous mode.

Tracking provides a predictable way of slewing the output voltages up or down. Tracking generally holds the feedback voltage to the lesser of the internal reference voltage or the voltage on a TRACK pin. The LTC3850 goes farther by combining track and soft start functions in a single pin for each channel and by tailoring the mode of switching operation to the state of the TK/SS pins.

When TK/SS is ramping up from ground to 0.8V, either from its 1.3µA internal current source or by tracking another supply, the channel remains

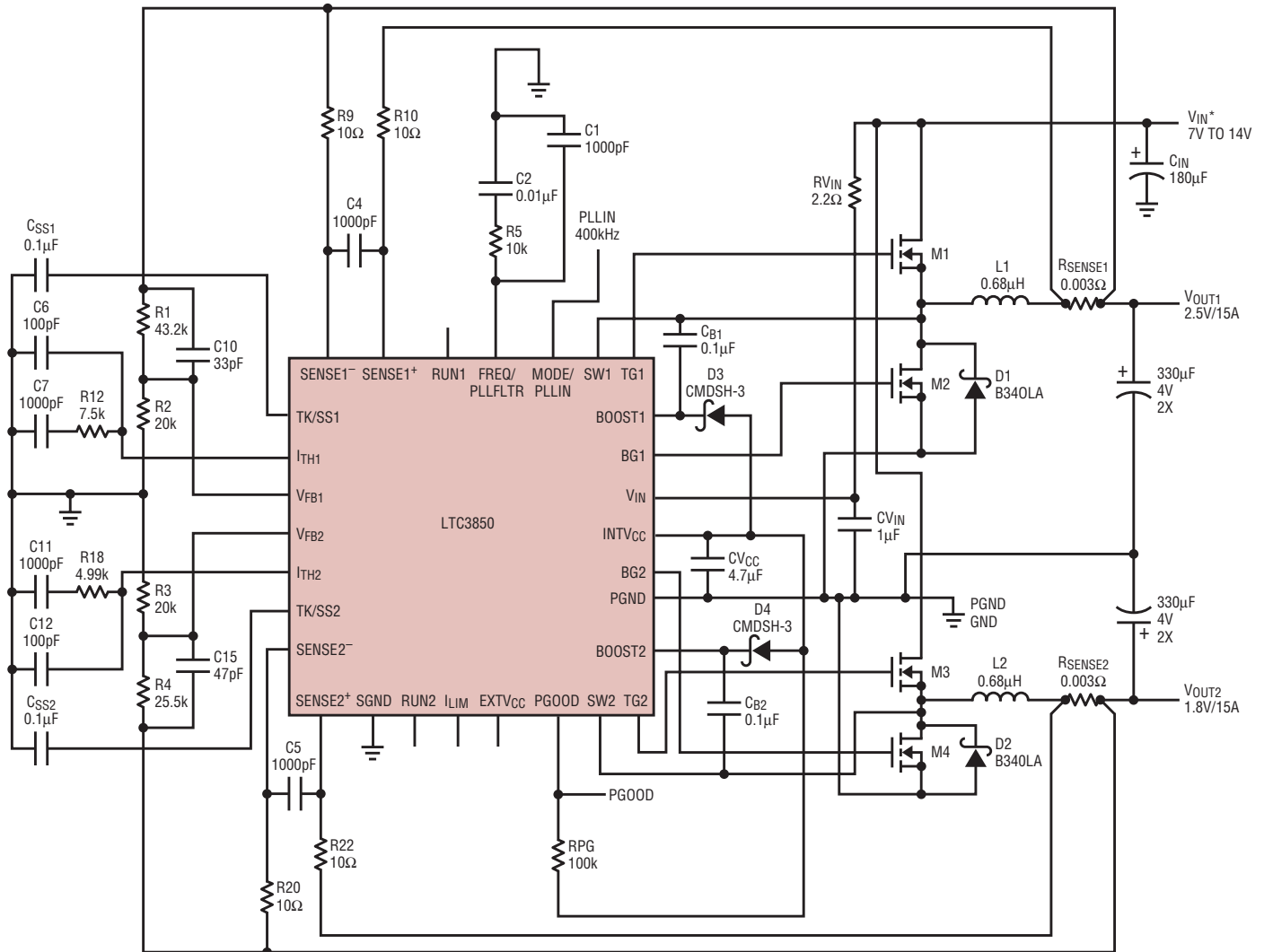

L1, L2: SUMIDA CEP125-OR6MC
 COUT1, COUT2: SANYO 4TPD330M
 M1, M3: RJK0305DPB
 M2, M4: RJK0301DPB

* FOR VIN = 5V ± 0.5V, TIE VIN AND INTVCC PINS TOGETHER.

Figure 5. Schematic for a 2-channel, 15A/400kHz regulator.

in pulse skipping mode until the TK/SS voltage reaches 0.64V. This prevents the regulator from sinking current from the output while it is at 80% or less of the target voltage. When TK/SS ramps up from 0.64V to 0.74V, the channel operates in forced continuous mode to ensure that the power good indicator (PGOOD) makes just one transition from low to high when the output comes into regulation (within $\pm 7.5\%$ of the precision 0.8V reference). Once 0.74V (the undervoltage threshold) is reached, the regulator transitions to the mode of switching operation programmed on the MODE/PLLIN pin. When TK/SS is descending from 0.8V, forced continuous mode takes over when $V_{TK/SS}$ and V_{FB} ramp from 0.74V down to 0.1V, allowing the LTC3850 to pull down the output at the programmed slew rate. Once TK/SS ramps down to 0.1V, the channel begins operating in pulse skipping mode. Switching stops when TK/SS is less than the feedback voltage.

Each channel also features a separate RUN pin with a precision 1.2V turn-on threshold. When the LTC3850's own current source is used to charge the soft-start capacitor, bringing a channel's RUN pin high causes its soft-start capacitor to begin charging within about 80 μ s. As an alternative, either RUN pin can remain high while TK/SS is held low, which keeps the internal 5V regulator enabled as a standby supply. This feature can be used to power a wake-up circuit which controls the state of both TK/SS pins.

Two Ways to Sense Current

The LTC3850 features a fully differential comparator to sense current through the inductor. The SENSE⁺ and SENSE⁻ pins can be connected to a sense resistor in series with the inductor, or to an RC network in parallel with the inductor for energy efficient sensing across the inductor's DC resistance (DCR sensing). Using 1% tolerance sense resistors offers an accurate current limit, but incurs I^2R losses in the resistors. DCR sensing prevents this power loss, but uses a sense element with a typical built in

The LTC3850's two channels run out of phase, which reduces the input RMS current ripple and thus the input capacitance requirement.

error of 5%-10%. The LTC3850 can use either method, with a choice of three pin-selectable current limits.

When an output sees a short circuit, the LTC3850 protects the input supply and power components by limiting peak current cycle by cycle. The main MOSFET turns off when the inductor's peak current sense threshold ($V_{SENSE(MAX)}/R_{SENSE}$) is reached.

$V_{SENSE(MAX)}$ can be set to 30mV, 50mV, or 75mV, for a wide range of output current levels. Duty cycle has little effect on this current limit (Figure 2). For load currents greater than the programmed maximum but less than a hard short, the LTC3850 gracefully folds back the top MOSFET's on-time, reducing the output voltage.

The LTC3850 also protects against undervoltage input and overvoltage output voltages. The RUN pins can be referenced to a voltage divider from V_{IN} , so that their precision thresholds control the state of the outputs. If the output voltage is more than 7.5% above its target, the bottom MOSFET can remain on until regulation is recovered. If the LTC3850 is allowed

continued on page 16

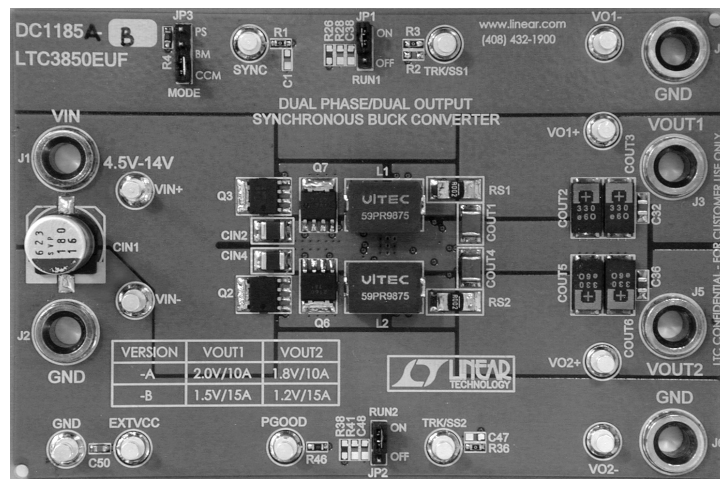

a. Top view

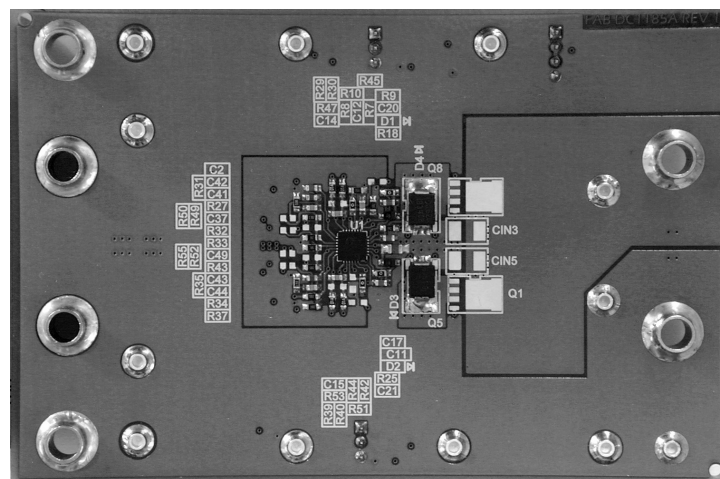

b. Bottom view

Figure 6. The circuit of Figure 5 can be laid out inside a square inch on a two-layer board.

Measure Microamps to Amps or Reduce Power Dissipation by 99%, You Decide!

by Brendan J. Whelan

Introduction

A required, but often overlooked, element of any industrial or automotive monitoring/control system is a current sensing circuit that can maintain accuracy over the entire load range. Many applications use circuits that can provide only moderate precision and dynamic range. In many cases the current sense solution is woefully inadequate, with poor resolution and significant power dissipation in the sense resistor. The LTC6102 addresses both of these problems while boosting performance via a comprehensive set of current sense features.

Why Use High Side Sense?

In many applications, the sense load is ground referred. The simplest way to measure current in these systems is low side sensing, which involves adding a small sense resistor between the load and the system ground (Figure 1). Almost any amplifier can be used to amplify the sense voltage, and no level translation is required.

Low side sensing, for all its simplicity, has several inherent problems. First, the sense resistor affects the return voltage on the load—where the return is now the sum of the system's ground potential and the voltage across the sense resistor. The load now floats above system ground by the sense voltage, which can be significant—a traditional low side current sense circuit of some precision requires a voltage around and above 100mV.

Of course, as the load current changes, the sense voltage reacts as it should, thus affecting the ground potential seen by the load. A moving ground reference is no reference at all, resulting in load errors and significant noise. Transient load currents can present the load with tremendous

ground noise, reducing the performance of the monitoring system and injecting this noise directly into the load.

Second, there may be coupling between the load and ground, due to shielding. This coupling can alter the effective resistance of the sense resistor, especially over frequency, thereby reducing system performance.

Finally, safety may be compromised. In the event that the sense resistor fails, or becomes disconnected, the ground node of the load is energized to the full supply voltage. This is a safety hazard, as the node that is normally connected to ground is now held at dangerous potentials. It may not be obvious that such a fault has occurred, so it may be assumed that the ground terminal of the load is held at a safe voltage. Low voltage circuitry tied to the grounded side of the load may also be damaged, thus requiring additional work and expense in repair.

High side sensing eliminates these problems by allowing the system load to be safely and securely referred to ground. The high side of the load can be measured relative to ground without the sense resistor noise. The sense resistance can be more carefully controlled. Most importantly, a fault in the sense resistor disconnects the load from the supply, not ground, so safety is assured.

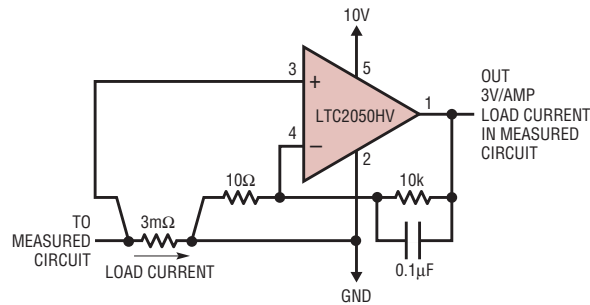

Figure 1. Classic high precision low side current sense

So, why isn't high side sensing used more often? The problem is that these advantages are tempered by a lack of simplicity. First, high supply voltages with high voltage transients demand a robust monitoring circuit. Second, the sense voltage must be accurately translated to ground. The LTC6102 addresses both of these problems with ease, while adding additional features to maximize accuracy and flexibility.

Solve the Dynamic Range Problem

It is no great technical feat to measure high load currents, but accurately monitoring high currents and low

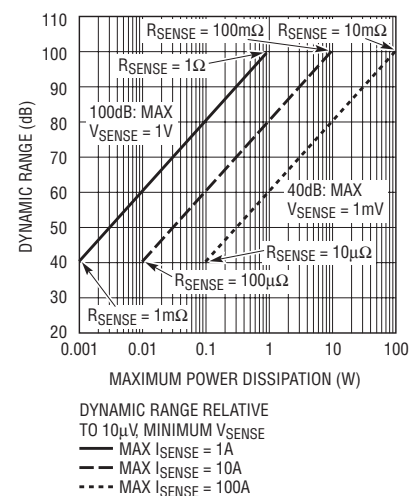

Figure 2. Dynamic range vs maximum power dissipation in R_{SENSE}

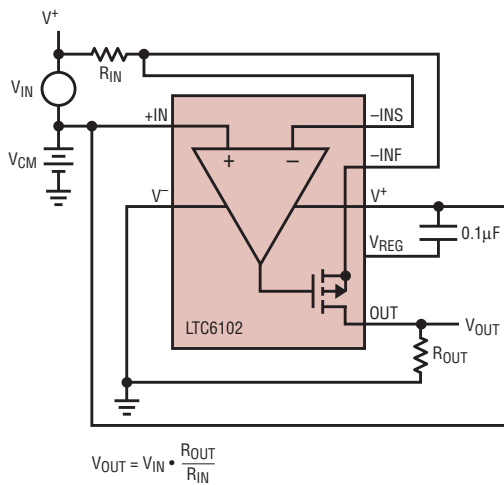

Figure 3. Level translation

currents on the same line, or resolving very small variations on large load currents, requires a monitoring circuit with a wide dynamic range. For example, a system that typically runs at 1A, but has dynamic loads up to 100A, would require at least 40dB of dynamic range for accurate measurement. If the typical load current must be measured with 1% accuracy, then 80dB of dynamic range is required. A battery system that calculates total battery charge over a range of load currents from 1mA to 100A would require 100dB or more!

For many current monitoring circuits, the dynamic range is limited at the high end by the maximum input voltage of the current sense amplifier, usually specified between 100mV and 500mV for integrated high side current sensing amplifiers. At the low end, input offset voltage limits the resolution. V_{OS} can be >1mV for many available integrated circuits, resulting in a dynamic range of 40dB–50dB, which is inadequate for many systems. The resolution is further degraded over temperature as the input offset can drift significantly.

The LTC6102 solves this problem by providing a maximum offset voltage of 10µV with a drift of less than 50nV/°C. The maximum input voltage of the part is 2V, giving a dynamic range of 106dB and a minimum resolution of 10µV. In simple terms, this allows a system to measure currents from 1mA to 200A without changing gain

or over-ranging. Current sense circuits that use the LTC6102 can easily be designed to provide high precision while accommodating temporary current surges or dropouts. This allows more accurate end-of-charge calculation and improved overall reliability.

Don't Need Dynamic Range? Trade in Dynamic Range for Reduced Power Loss

If you don't need to measure a large range of currents, the built-in dynamic range of the LTC6102 allows the use of very low value resistors. Reducing value of the sense resistor translates directly to improved power dissipation.

For instance, only 40dB of dynamic range is required for a system that must measure currents from 1A to 100A. Nevertheless, if a sense amplifier with 1mV input offset is used, then the maximum sense voltage must be no less than 100mV. At 100A, this dissipates 10W in the sense resistor. For accurate resistance at this high dissipation, a large, expensive custom sense resistor may be required, as well as a heat sink. The system must also be designed to provide the additional 10W, plus it must dissipate the resulting heat effectively.

If, however, the LTC6102 is used for this current measurement, then the maximum sense voltage can be reduced to 1mV without degrading performance. In fact, the low drift of the LTC6102 can provide improved precision over temperature when compared to other solutions. At the same time, dissipation is reduced to 100mW, a 99% reduction in power dissipation in the sense resistor, significantly simplifying or eliminating thermal design requirements.

Figure 2 shows the dynamic range vs power dissipation for 1A, 10A and 100A loads. Each line represents a fixed current. Dynamic range and power dissipation are optimized by adjusting the value of the sense resistor (R_{SENSE}). The sense resistor extremes are illustrated in the figure. It is easy

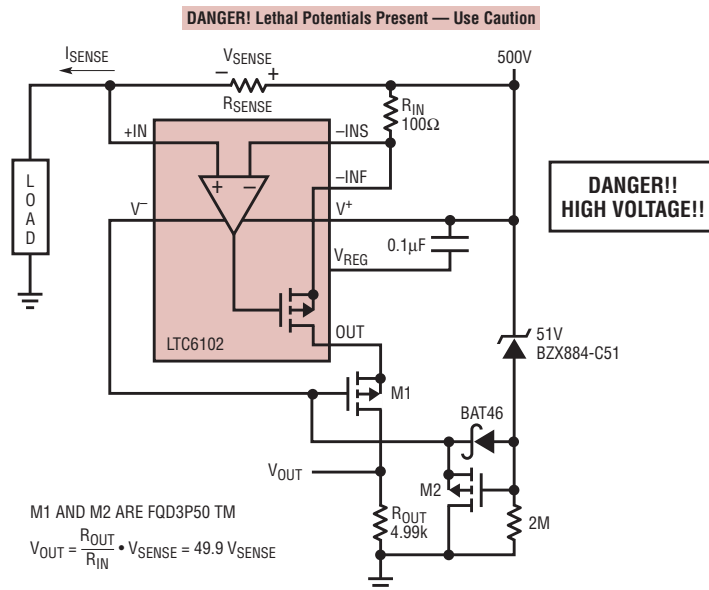

Figure 4. Simple 500V current monitor

to adjust the circuit performance using available sense resistor values. Dynamic range is the ratio between the maximum voltage across the sense resistor and the input offset of the LTC6102, while power dissipation is the power dissipated in the sense resistor at the listed current.

Precision Level Translation

Unlike many application-specific current sensing amplifiers, the architecture of the LTC6102 is similar to standard operational amplifiers. The design includes high impedance inputs and external feedback as well as low input offset. This allows the LTC6102 to be used in a variety of voltage amplification circuits as well as current sensing applications. Because of its inherent level translation capability, the LTC6102 can amplify a wide variety of signals while simultaneously rejecting the common-mode component.

Figure 3 shows a level translation circuit that amplifies a voltage signal. The LTC6102 mirrors the input voltage onto R_{IN} , which is then translated to R_{OUT} . It is important to note that in this circuit the supply pin of the LTC6102 is tied to the negative terminal of the input signal. Both input pins are within a few microvolts of the supply pin, so the input voltage may exceed the full scale input range of the LTC6102 without introducing an error in the output. This circuit works as long as the current through R_{IN} , defined as V_{IN}/R_{IN} , does not exceed

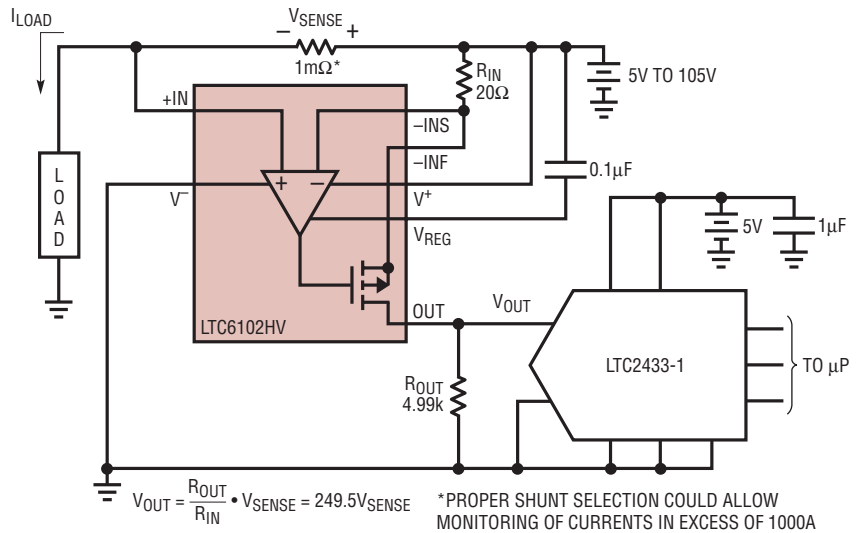

Figure 5. 10A current sense with 10mA resolution and 100mW maximum dissipation

the maximum output current of the LTC6102. If $R_{IN} = 10k\Omega$, then the input voltage can be as large as 10V. The gain is still set by R_{OUT}/R_{IN} , so either gain or attenuation may be chosen to allow the input signal to be translated to a useful output signal.

Simple and Flexible Design

The high precision and wide dynamic range of the LTC6102 are just the tip of the iceberg. A collection of features make the part easy to use, robust and flexible for many applications.

Wide Supply Range

The LTC6102 is specified for operation from 4V to 60V, and survives 70V supplies. The LTC6102HV is specified for operation up to 100V, with a maximum of 105V. In addition, just a few

external components can increase the operating voltage to several hundred volts or more without a loss of precision (Figure 4).

High Impedance Inputs

Unlike current-steering type sense amps that have input bias currents of several microamperes, the LTC6102 has <100pA input bias, allowing measurement of very small currents.

Simple, Flexible Gain Control

The gain of the LTC6102 can be set with two external resistors. Gain error is limited only by these external components, not poorly specified internal resistors or saturation voltages. The external input resistor allows a wide choice of gains, as well as control of input and output impedances. For example, choosing a small input resistor allows large gain with relatively small output impedance, reducing noise and making it easier to drive an ADC without additional buffering.

Open-Drain Output

Additional flexibility and performance are provided by the open drain output. With no internal pull down device, the minimum output voltage is not limited by a saturation voltage, so the output can drive all the way to ground. The output can also be referred to a voltage above ground simply by connecting the output resistor to that voltage. The sensing circuit can be physically

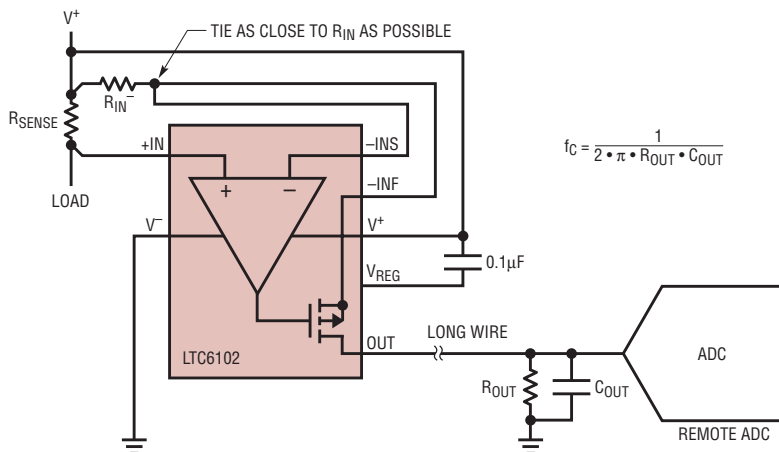

Figure 6. Remote current sense with simple noise filter

located far from the ADC without losing accuracy due to the resistance of the long output wire. The output can also be cascaded for additional level-shifting capability.

High Speed

The LTC6102 can support signals up to 200kHz, allowing the monitoring of fast-changing load currents. High speed also allows the LTC6102 to settle quickly after load transients, providing uninterrupted precision.

Fast Response Time

Protection circuitry must often react within microseconds to avoid system or load damage during fault conditions. The LTC6102 can respond to an input transient in 1 μ s. The output signal may then be used to turn off a MOSFET pass device or turn on a load protection circuit before system damage occurs.

Kelvin Input

The copper traces on the PC Board add to R_{IN} , creating a gain error that drifts 0.4%/°C. By connecting $-IN$ very near to R_{IN} , this effect is minimized, so very small (1 Ω or less) input resistors may be used. Small input resistors allow large gains with relatively small output impedance. Reducing the effect of parasitic series resistance also helps maintain large dynamic range, even with relatively large input resistors.

All That and Small Size, Too

Today's applications don't just require precision; they also need it in the smallest package possible. In order to meet that demand, the LTC6102 is available in a 3mm \times 3mm DD package, which requires no more board than a SOT-23. Where space is not such a premium, or where a leaded package is desired, the LTC6102 is also available in an 8-lead MSOP package.

Applications

Figure 5 depicts a simple current sensing circuit. R_{SENSE} converts the load current to a sense voltage. The LTC6102 applies a gain of 249.5 and shifts the level of the signal from the positive supply to ground. The sense resistor value may be chosen to maximize the dynamic range by setting a large maximum sense voltage (V_{SENSE}), or to limit power dissipation by choosing a smaller value. The high gain is made possible by both the Kelvin input, which allows the use of a small input resistor with little gain error, and the very low input offset, which produces less than 2.5mV error at the output. The small input resistor allows R_{OUT} to be set to 4.99k, which is small enough to be compatible with high resolution converter inputs. The addition of an LTC2433-1 is a simple way to convert the result.

For systems that are subjected to electrical interference, or for remote sensors, a capacitor may be placed

across R_{OUT} to filter the output, reducing noise and high frequency interference (Figure 6). This adds a simple pole to the output without affecting the DC result. In remote sensing, the LTC6102 should be placed in the sensor location, and the output can be run long distances to a converter. Since the output is current, not voltage, there is no loss in the wire. The output resistor and capacitor should be placed at the processor end of the wire to reduce noise and ensure accuracy.

Conclusion

Many current sensing applications can benefit from a high side sense method. High side current sensing circuits must be able to work at high voltages determined by the supply range, even under fault conditions, and must usually level-shift the signal to ground or another reference level. They must accomplish these tasks while preserving the precision and accuracy of the signal. The LTC6102 zero-drift current sensing amplifier offers the highest precision DC specifications. Wide supply range, low input offset and drift, accurate gain, fast response, and simple configurability make the LTC6102 and LTC6102HV ideal for many current sensing applications.

For a complete guide to current sense applications, visit www.linear.com/currentsense. 

LTC3850, continued from page 12

to operate with a main input voltage approaching the programmed output voltage, its duty cycle can be as high as 97%.

Dual Output, 5A Regulator with DCR Sensing

Figure 3 shows the schematic for a 500kHz, 2-output regulator requiring no sense resistors. By using the inductor's DC resistance as the current sense element, the application dissipates as little power as possible—at full load current, efficiency is well above 90%, as Figure 4 shows.

Dual Output, 15A Regulator with Sense Resistors

Figure 5 shows the schematic for an efficient 400kHz, 2-output regulator. Figure 6 shows that this circuit's core occupies less than a square inch on a 2-layer board. Peak inductor current is limited to 25A by the maximum current sense threshold looking across the sense resistor (50mV / 2m Ω). Taking inductor ripple current into account, the output current limit is around 20A for each channel. Higher load current will cause the LTC3850 to protect the power stage using current foldback.

Conclusion

The LTC3850 delivers copious features in small packages. Available in 4mm \times 4mm 28-pin QFN (0.4mm lead pitch), 4mm \times 5mm 28-pin QFN (0.5mm lead pitch), or 28-pin narrow SSOP, it can run at high efficiency using DCR sensing and Burst Mode operation. Tracking, strong on-chip drivers, multiphase operation, and external sync capability fill out its menu of features. Ideal for notebook computers, PDAs, handheld terminals and automotive electronics, the LTC3850 delivers multiphase power to mission critical applications. 

Pushbutton On/Off Controller Provides μ Processor Reset Monitor and Input Supply Monitoring

by Victor Fleury

Introduction

System designers often grapple with ways to debounce and control the on/off pushbutton of portable devices. Traditional debounce designs use discrete logic, flip-flops, resistors and capacitors. Some designs require an onboard microprocessor to monitor the pushbutton, but this puts a burden on the microprocessor—if it hangs up, *all* device on/off control is lost. Also, in high voltage, multicell battery applications the low voltage circuits require an LDO power supply. In the end, what should be a simple monitoring circuit consumes an oversized share of the space and complexity of the system. Plus, its draw on the power budget is high even when the system is off, since the microprocessor must keep awake, constantly watching the pushbutton.

The LTC2953 pushbutton on/off controller with voltage monitoring alleviates the headaches of discrete implementations and provides a self-contained alternative to microprocessor based pushbutton monitoring. The LTC2953 integrates all the flexible timing circuits needed to debounce the on/off pushbutton of portable systems and provides a simple yet powerful interface that allows for controlled power up and power down.

The part also includes input and output supply monitors. A power fail comparator issues an early warning when it detects a low battery condition, while a UVLO comparator prevents a user from applying system power from a dead battery (or low supply). Additionally, an adjustable single supply supervisor provides a 200ms reset output delay after the monitored supply rises above the programmed voltage.

The LTC2953's wide input voltage range (2.7V to 27V) is designed to operate from single-cell to multicell

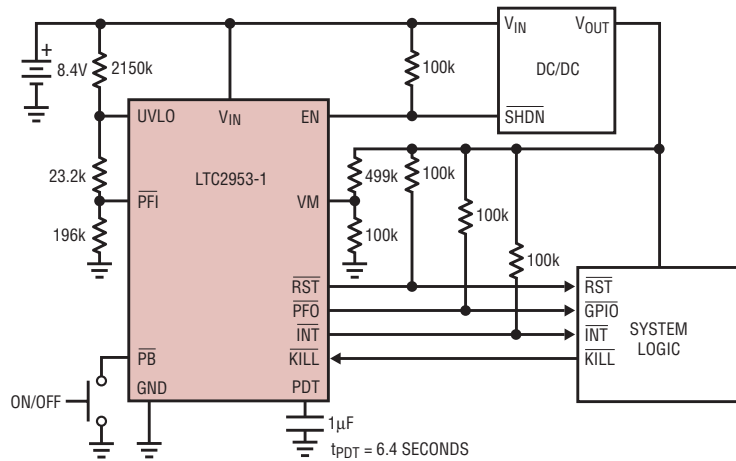

Figure 1. A complete pushbutton and voltage monitoring system is easy to set up with the LTC2953-1.

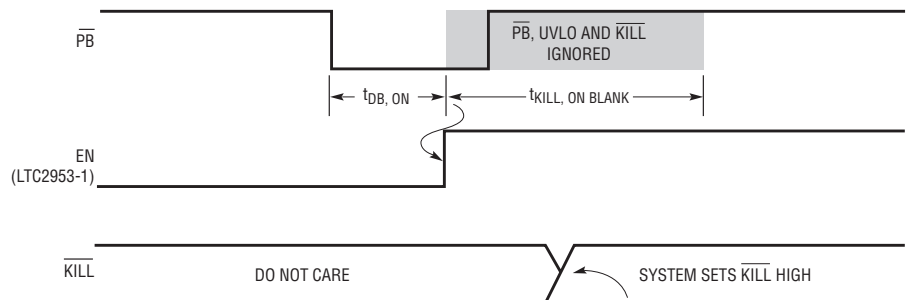

Figure 2. Timing diagram shows a pushbutton-controlled system power on.

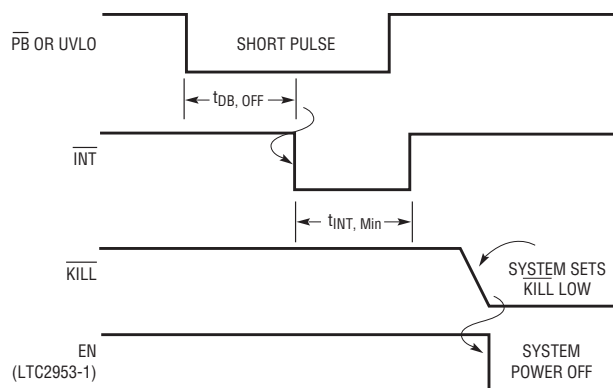

Figure 3. Timing diagram for normal power off sequence

battery stacks, thus eliminating the need for a high voltage LDO. The part's features allow the system designer to turn off power to all circuits except the LTC2953, whose very low quiescent current (14 μ A typical) extends battery life. The device is available in a space saving 12 lead 3mm \times 3mm DFN package.

Orderly Power On

The pushbutton input of the LTC2953 controls the logic state of the open drain enable output. Figure 1 shows the EN output of the LTC2953-1 driving a DC/DC converter. To turn on system power, the pushbutton input must be debounced (held low continuously for at least 32ms). See the timing diagram shown in Figure 2. Note that once power has been enabled, the system must set the $\overline{\text{KILL}}$ input high within 512ms.

Orderly Power Off

The LTC2953 provides two ways to manually turn off system power: issuing an orderly power off request, and forcing an immediate power off. An orderly power off involves a simple push and release of the on/off button. For instance, for the circuit in Figure 1, if an end user is using an MP3 player, he presses and releases the on/off button, which subsequently drives the $\overline{\text{INT}}$ output low for a minimum of 32ms. The system logic that monitors the LTC2953's $\overline{\text{INT}}$ output then initiates various pre-power-down and housekeeping tasks, and asserts $\overline{\text{KILL}}$ low when all is well. The LTC2953 then shuts down the DC/DC converter—turning off system power. See the timing diagram shown in Figure 3.

The other type of shutdown is a manual reset. This allows the user to force power off if the system logic or μ P fails to respond to the interrupt signal. To do so, the end user presses and holds the pushbutton down. The length of time required to force a power down is given by a fixed internal 64ms delay plus an adjustable power down timer delay. The adjustable delay is set by placing an optional external capacitor on the PDT pin. See Figure 4.

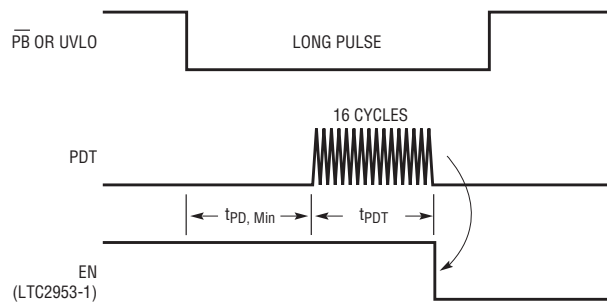

Figure 4. Timing diagram for forced power off, in the case where the user must bypass system logic control.

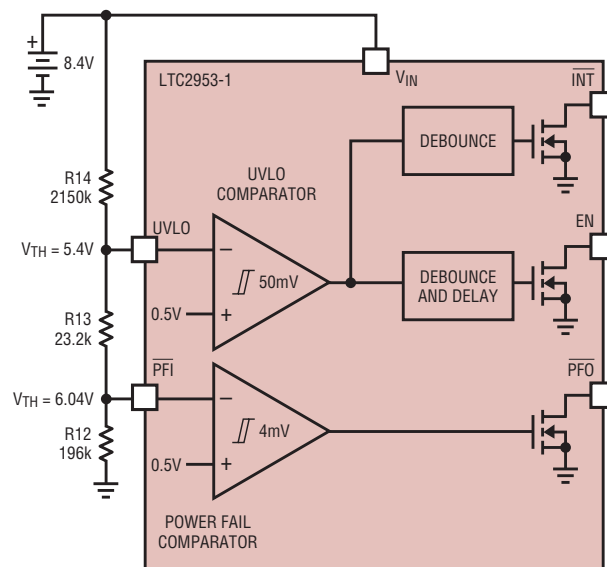

Figure 5. De-glitched UVLO comparator monitors battery stack

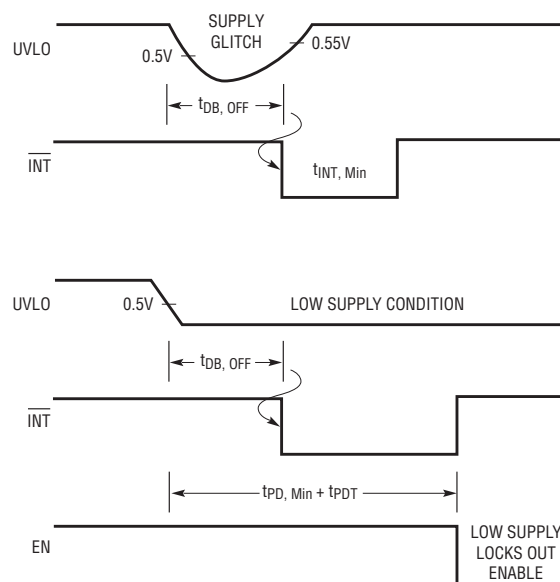

Figure 6. Low supply initiates system power down and locks out enable

Table 1. Pushbutton product family

Part Number	Supply Voltage (V)	Supply Current (μ A)	ON Timer	OFF Timer	Kill Timer	Comments	Package
LTC2950	2.7 to 26	6	Adj	Adj	1024ms	Active high enable output (LTC2950-1) Active low enable output (LTC2950-2)	TSOT-8 DFN-8
LTC2951	2.7 to 26	6	128ms	Adj	Adj	Active high enable output (LTC2951-1) Active low enable output (LTC2951-2)	TSOT-8 DFN-8
LTC2952	2.7 to 28	25	Adj	Adj	Extendable	Pushbutton PowerPath controller with system monitoring	TSSOP-20 QFN-20
LTC2953	2.7 to 27	14	32ms	Adj		Pushbutton controller with supply monitor, UVLO and power fail comparators	DFN-12
LTC2954	2.7 to 26	6	Adj	Adj		Interrupt logic for menu driven applications. Active high enable output (LTC2954-1) Active low enable output (LTC2954-2)	TSOT-8 DFN-8

Power Fail Comparator Issues Low Supply Warning

The LTC2953 provides an uncommitted power fail comparator that can serve as the first warning of a decaying battery or a low supply. The $\overline{\text{PFO}}$ output is driven low when the $\overline{\text{PFI}}$ input voltage drops below 0.5V. This comparator provides real time supply information and does not affect the functionality of the enable and interrupt outputs. A system designer can use the power fail comparator to identify the source of a power down interrupt request: the pushbutton or the UVLO. If the $\overline{\text{PFO}}$ output is low when the interrupt output is asserted, then the UVLO input initiated the power down request (see Figure 5).

UVLO Comparator Rejects Short Supply Glitches

The application shown in Figure 5 monitors a 2-cell Li-Ion battery stack. The UVLO comparator has glitch immunity to prevent short spikes on the supply line from issuing a power down request. All glitches shorter than 32ms are ignored. If the battery voltage drops below 5.4V for longer than 32ms, however, the LTC2953 asserts the interrupt output for a minimum of 32ms. When both $\overline{\text{INT}}$ and $\overline{\text{PFO}}$ are driven low, this alerts the system logic that a significant battery glitch has occurred. For cases where the battery voltage falls and stays below

5.4V for an indefinite length of time, the LTC2953 automatically shuts off system power. See the Figure 6 timing diagram.

UVLO Locks Out Pushbutton Input

The LTC2953 prevents a user from turning on system power with a dead battery or low supply. If system power is off and the voltage on the UVLO input is below 0.5V, the pushbutton input is ignored. This means that if a battery or

supply drops below a predetermined adjustable level, the LTC2953 does not allow system power on (see Figure 6 timing diagram).

Pushbutton Controlled Supply Sequencing

The circuit in Figure 7 uses the LTC2953-2 to sequence three supply rails. Power on supply sequencing begins by pressing the pushbutton for 32ms. This asserts the $\overline{\text{EN}}$ output low, which turns on the V1 supply.

continued on page 42

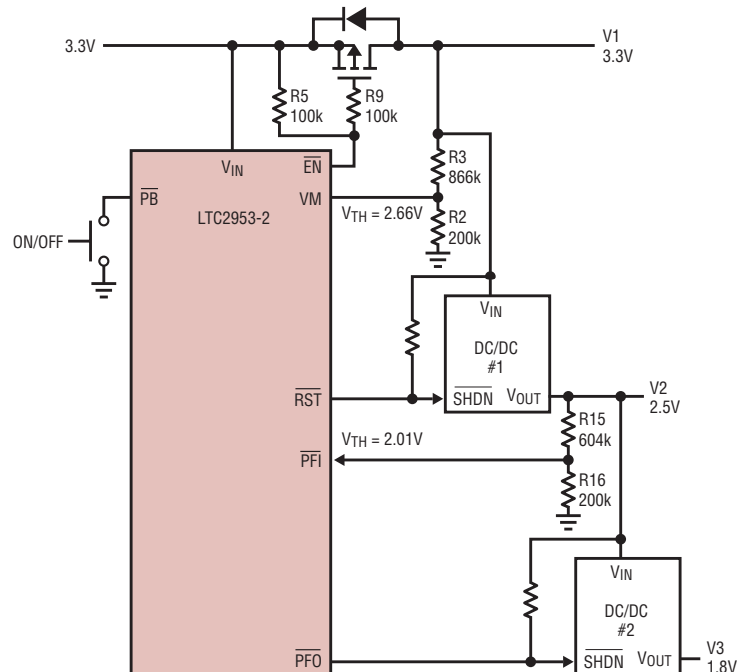

Figure 7. Pushbutton controlled supply sequencing

LED Driver Yields 3000:1 True Color PWM Dimming with Any Buck, Boost or Buck-Boost Topology from a Wide 3V–40V Input Range

by Xin Qi

Introduction

High power LEDs are quickly expanding their reach as a light source for TV projection, scanners, and various automotive and avionic products. All require a constant LED current, whether in buck, boost, buck-boost or SEPIC configurations. Pulse Width Modulation (PWM) is the preferred dimming method for these LED systems to preserve LED color over a wide dynamic range of light intensities. The LT3518 is a highly integrated 2.3A full-featured LED driver capable of providing 3000:1 True Color PWM™ dimming ratio in a variety of topologies for high power LED driver applications.

The LT3518 features a 45V power switch, 100mV high side current

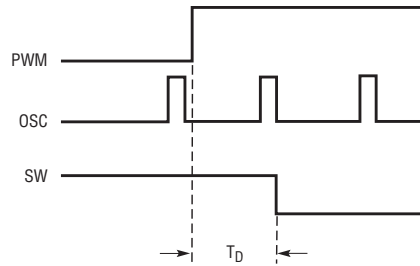

Figure 1. Regular LED driver timing diagram

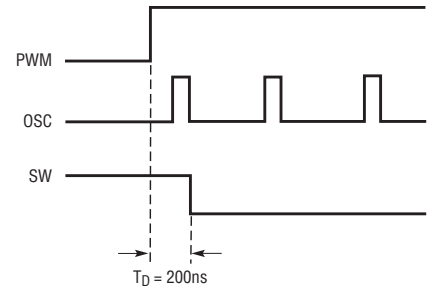

Figure 2. LT3518 timing diagram

sense and accurate open LED protection. It combines a traditional voltage feedback loop and a current feedback loop to operate as a constant current and/or constant voltage source. The programmable soft-start limits inrush current during startup, preventing

input current spikes. The LT3518's wide operating input range of 3V to 40V makes it ideally suitable for automotive applications. The 10:1 analog dimming range further extends the total dimming range to 30,000:1. A PMOS disconnect switch driver is integrated to improve the transient response to the PWM control signal. The programmable operating frequency of 250kHz to 2.5MHz allows optimization of the external components for efficiency or component size. To reduce switching noise interference, the LT3518 is synchronizable to an external clock.

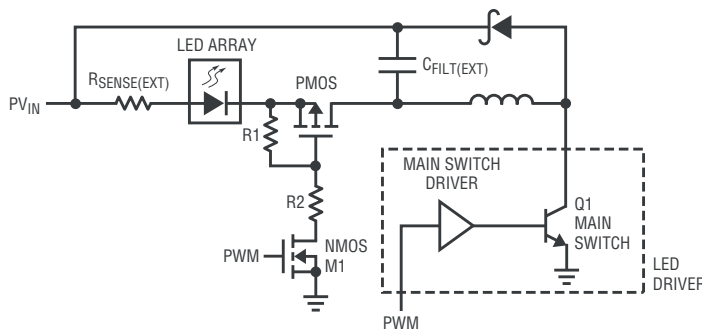

Figure 3. External PMOS disconnect switch driver for a conventional LED driver

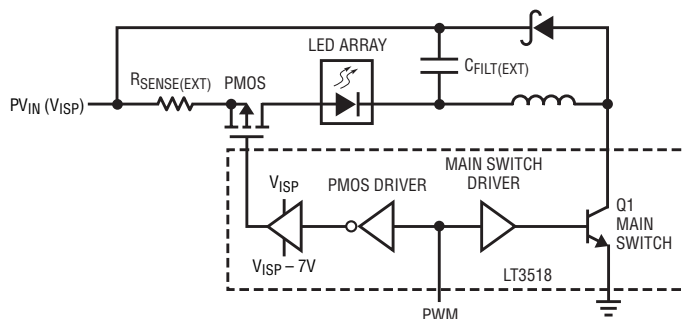

Figure 4. LT3518 internal PMOS driver

Highly Effective PWM Dimming Control

Alignment of Internal Clock and External PWM signal

Most LED drivers operate with an independent, free-running internal oscillator. Each switching cycle begins when the internal oscillator transitions from high to low. When PWM dimming, the switch is turned off when the PWM signal is low. After the PWM signal is driven high, the switch has to wait for the next oscillator high-low transition to turn on, as shown in Figure 1. The turn on delay varies from 0 to one full oscillator cycle, which limits

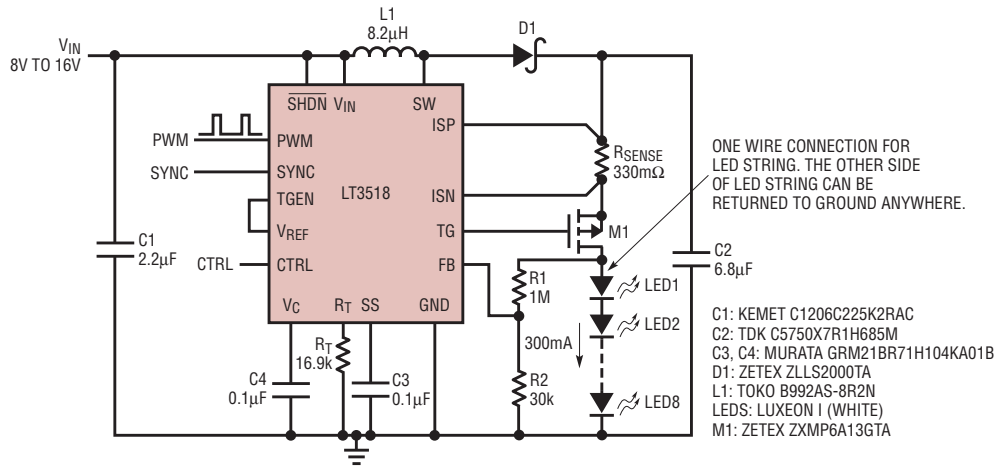

Figure 5. 1-wire boost 300mA LED driver with LED open protection

the achievable PWM dimming ratio. This extra cycle becomes an obstacle when high PWM dimming ratios are required.

The LT3518 adopts a new timing scheme, illustrated in Figure 2, to run the converter. Instead of using a free-running oscillator, the LT3518 aligns the internal oscillator to the external PWM signal. When the PWM signal is low, the internal clock is disabled. The PWM rising edge wakes up the internal oscillator with a fixed 200ns delay. In this manner, the LT3518 has a fast response to the PWM input signal, thus improving the achievable PWM dimming ratio.

PMOS Disconnect Switch Driver

Recent LED driver designs disable all internal loads to the Vc pin during the PWM low period, which preserves the charge state of the Vc pin on the external compensation capacitor. This feature reduces the transient recovery time, further increasing the achievable PWM dimming ratio. However, to achieve the best PWM dimming ratio

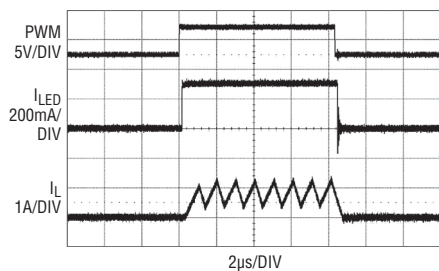

Figure 6. PWM dimming waveform for Figure 5 at 120Hz PWM frequency and VIN = 10V

for a buck/buck-boost mode LED driver, other ICs still rely on several additional external components to drive a PMOS disconnect switch. As

The LT3518's wide operating input range of 3V to 40V makes it ideally suitable for automotive applications.

shown in Figure 3, a typical PMOS disconnect switch driver consists of an NMOS transistor and a level shift resistor network formed by R1 and R2. This kind of PMOS driver must juggle

the tradeoffs between fast transient response and high power consumption. The diverse input voltage and LED voltage combinations also make the level shifter design difficult.

In contrast, the LT3518 incorporates a PMOS driver inside, which can transition a 1nF gate capacitance PMOS switch in 200ns with a small holding current, typically 600µA. In this way, the LT3518 simplifies board layout, reduces the bill of material, and avoids the dilemma of trading off the power consumption for a fast transient response. Additionally, the LT3518 includes an internal level shifter to ensure the that the TG pin

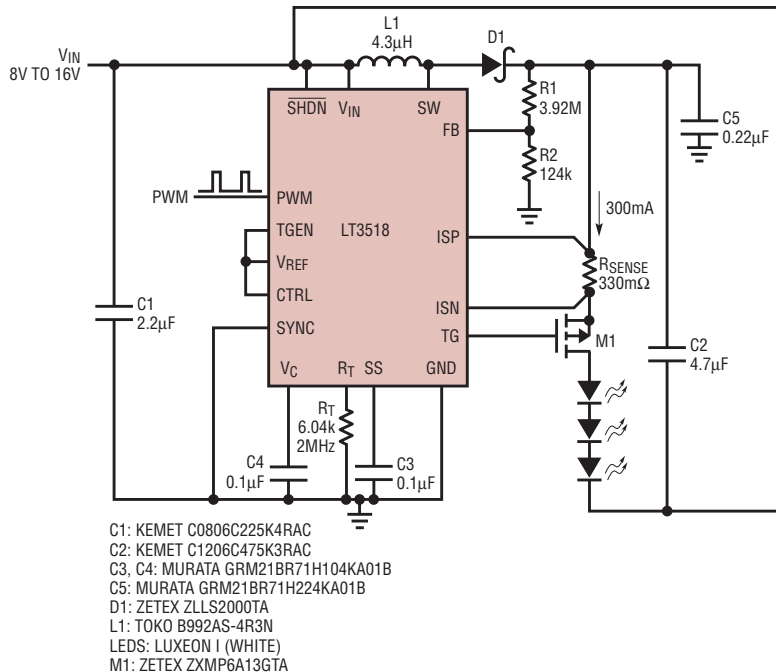

Figure 7. Buck mode LED driver

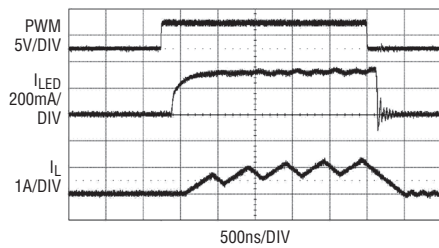

Figure 8. 3000:1 PWM dimming waveform of application circuit of Figure 7 at 120Hz PWM frequency and $V_{IN} = 12V$.

is 7V or less below ISP pin. The internal PMOS driver can also be used to implement fault protection. When a fault is detected (e.g., an input surge), the LED array will be disconnected and protected by pulling down the PWM input.

Applications

1-Wire High PWM Dimming Boost LED Driver

Many LED drivers feature high side current sensing that enables the parts to function as a 1-wire current source. To improve PWM dimming ratio in boost configuration, those LED drivers typically rely on a low side NMOS disconnect switch, unfortunately limiting the 1-wire operation. On the contrary, the unique internal PMOS driver of the LT3518 makes 1-wire operation feasible in boost configuration while keeping a high PWM dimming ratio. Figure 5 shows the LT3518 driving eight 300mA LEDs in boost configuration. This setup only needs to provide 1-wire for the top side of the LED string, while the other side of the LED string can be returned to ground anywhere. Figure 6 shows a 1000:1 PWM dimming waveform captured by using this setup.

Buck-Boost PWM LED Driver

For an application in which the V_{IN} and V_{OUT} ranges overlap, a buck-boost topology is preferred. To make the LT3518 with a low side switch function as a buck-boost converter, the LED current should be returned to V_{IN} . Thus, the LEDs see a voltage of $V_{OUT} - V_{IN}$. Figure 7 depicts a buck-boost PWM LED driver for automotive applications. In this setup, the single

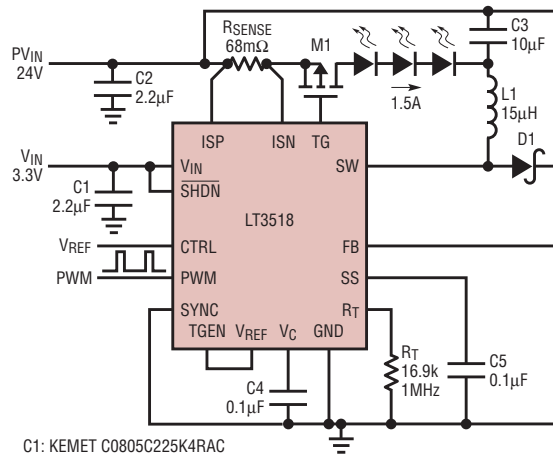

- C1: KEMET C0805C225K4RAG
- C2: MURATA GRM31MR71E225KA93
- C3: MURATA GRM32DR71E106KA12B
- C4, C5: MURATA GRM21BR71H104KA01B
- D1: ZETEX ZLLS2000TA
- L1: TOKO B992AS-150M
- LEDs: LUXEON K2 (WHITE)
- M1: ZETEX ZXMP6A13GTA

Figure 9. 500mA, 5V to 12V boost converter with accurate input current limit

battery input voltage is able to vary from 8V to 16V. The 6.04kΩ R_T resistor sets the system up for 2MHz switching, which permits a higher PWM dimming ratio than the standard 1MHz switching frequency. The 3000:1 PWM dimming ratio shown in Figure 8 is achieved at 120Hz PWM frequency.

High Current Buck PWM LED Driver

The LT3518 features a 2.3A switch, which makes it capable of driving 1.5A LEDs in buck configuration. Special attention should be paid to the internal power consumption when driving high current LEDs. Both high switching frequency and high power input voltage (PV_{IN}) tend to cause high power consumption and heat up the silicon. With 1MHz switching frequency and 24V PV_{IN} , the circuit shown in Figure 9 can provide 1000:1 PWM dimming ratio as shown in the waveforms in Figure 10.

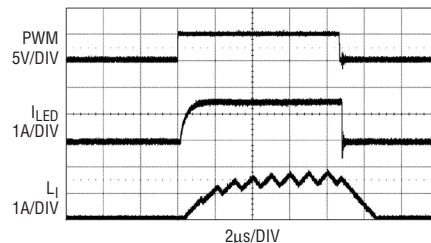

Figure 10. 1000:1 PWM dimming waveform of the application circuit of Figure 9 at 120Hz PWM frequency.

When a high power input voltage drives a few LEDs in buck configuration, open LED protection should be considered. Unlike the boost configuration, the output voltage needs to be level-shifted to a signal with respect to ground as illustrated in Figure 11. In this manner, the unique constant voltage loop of the LT3518 can regulate the output voltage of the buck configuration at the predefined value, thus protect LEDs.

Conclusion

The LT3518 is a high current, high voltage and high accuracy LED driver offering high PWM dimming ratios a variety of topologies. Its versatility, simplicity and reliability make it very attractive in most LED applications. The LT3518 is available in the tiny footprint QFN UF16 package and leaded FE16 package. It provides a complete solution for both constant-voltage and constant-current applications.

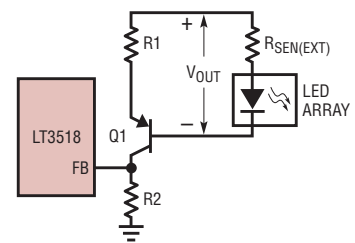

Figure 11. Open LED protection setup for buck configuration

White LED Driver and OLED Driver with Integrated Schottkys and Output Disconnect in 3mm × 2mm DFN

by Alan Wei

Introduction

The LT3498 is a dual boost converter featuring both an LED driver and OLED driver in a single 3mm × 2mm DFN package. It provides an internal power switch and Schottky diode for each converter as well as an output disconnect PMOS for the OLED driver. Both converters can be independently shutdown and dimmed. This highly integrated power solution is ideal for dual display portable electronics with tight space constraints.

The LED driver is designed to drive up to six white LEDs in series from a Li-Ion cell. It is capable of regulating the LED current in a series configuration, providing equal brightness throughout an LED string regardless of variations in forward voltage drop. The 2.3MHz switching frequency allows the use of small external components and keeps switching noise out of critical wireless and audio bands. It features a high side LED current sense, which allows the converter to be used in a wide variety of application configurations. The LED driver also contains internal compensation, open-LED protection, analog or PWM controlled dimming, a 32V power switch and a 32V Schottky diode.

The OLED driver of the LT3498 features a novel control technique resulting in low output voltage ripple as well as high efficiency over a wide load range. During operation, the converter controls power delivery by varying both the peak inductor current and switch off time. The off time is not allowed to exceed a fixed level, guaranteeing that the switching frequency stays above the audio band. This unique control scheme makes it ideal for noise sensitive applications such as MP3 players and mobile phones. When operated by itself, the OLED driver consumes a low 230µA quiescent current, extend-

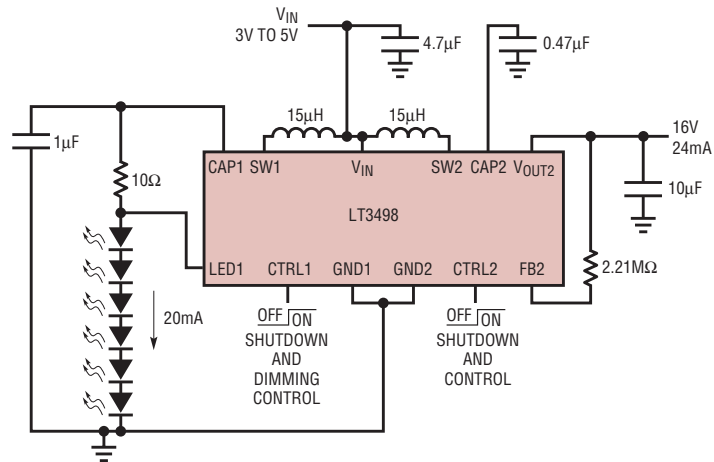

Figure 1. Li-Ion to six white LEDs and an OLED display

ing battery life in application modes where the LED driver is temporarily disabled.

Figure 1 shows a typical application driving 6 LEDs and an OLED. Figures 2 and 3 show the efficiency of the LED driver and OLED driver respectively.

Features

LED Driver High Side Sense

The LED driver of the LT3498 features a unique high side LED current sense that enables the part to function as a 1-wire current source. This allows

the cathode side of the bottom LED in the string to be returned to ground anywhere, resulting in a simple 1-wire LED connection. Traditional LED drivers use a grounded resistor to sense LED current, requiring a 2-wire connection to the LED string since the ground must return to the part ground. In addition, high side sense allows the LT3498 LED driver to operate in unique applications (buck mode or buck boost mode, where the LED string is returned to the input) where traditional LED drivers cannot be used.

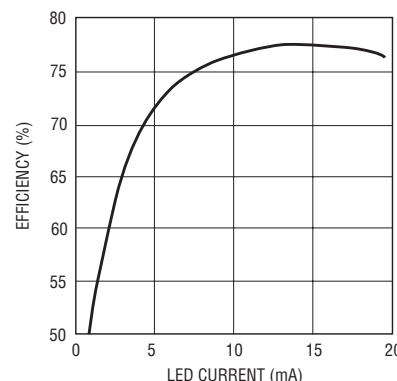

Figure 2. Efficiency of the LED driver in Figure 1

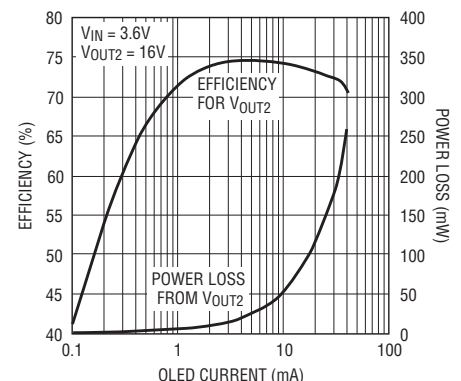

Figure 3. Efficiency of the OLED Driver in Figure 1

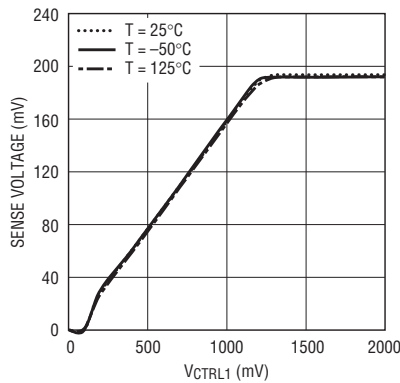

Figure 4. LED sense voltage vs CTRL1 pin voltage

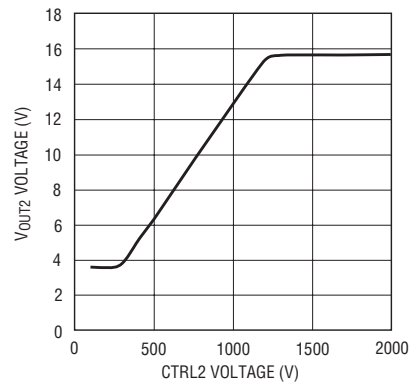

Figure 5. V_{OUT2} voltage vs CTRL2 pin voltage

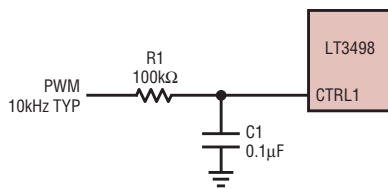

Figure 6. Filtered PWM dimming

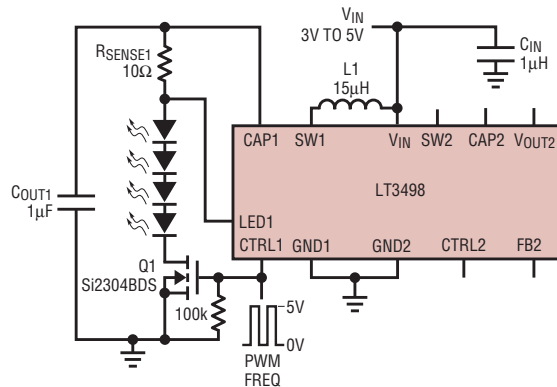

Figure 7. Li-Ion to four white LEDs with direct PWM dimming

Dimming & Shutdown Control

The LT3498 features a single pin shutdown and dimming control for each converter. To shutdown the LT3498, simply pull both control pins below 75mV. To enable each individual converter, increase the control pin (CTRL1 for the LED Driver and CTRL2 for the OLED Driver) voltage to 125mV or higher. On the LED side, the LED current can be set by modulating the CTRL1 pin. On the OLED side, the V_{OUT2} voltage can be set by modulating the CTRL2 pin. There are three types of dimming methods available in the LT3498: DC voltage dimming, filtered PWM signal dimming and direct PWM dimming.

The LED current and V_{OUT2} voltage are proportional to the DC voltages at the CTRL1 and CTRL2 pins, respectively. To dim the LEDs or lower the V_{OUT2} voltage, reduce the voltage on the CTRL1 and CTRL2 pins. The dimming range of the LED driver extends from 1.5V at the CTRL1 pin for full LED current down to 125mV. The CTRL1 pin directly controls the regulated sense voltage across the sense resistor that

sets the LED current (see Figure 4). The CTRL2 pin regulates the V_{OUT2} voltage in a similar fashion as shown in Figure 5.

Filtered PWM dimming works similarly to DC voltage dimming, except that the DC voltage input to the CTRL pins comes from an RC-filtered PWM signal. The corner frequency of the R1 and C1 should be much lower than the frequency of the PWM signal for proper filtering. Filtered PWM dimming is shown in Figure 6.

Direct PWM dimming is typically used because it achieves a much wider dimming range compared to using a filtered PWM or a DC voltage. Direct PWM dimming uses a MOSFET in series with the LED string to quickly connect and disconnect the LED string. Figure 7 displays direct PWM dimming of the LEDs in a Li-Ion to 4 white LED application. A PWM signal is applied to the CTRL pin and MOSFET where the PWM signal controls both the turn-on and turn-off of the part. Figure 8 shows the linearity of PWM dimming across a range of frequencies. The available dimming range depends on the settling time of the application and the PWM frequency used. The application in Figure 7 achieves a dimming range of 250:1 using a 100Hz PWM frequency.

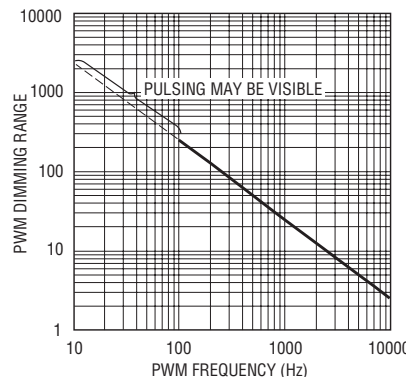

Figure 8. LED dimming range vs PWM dimming frequency

OLED Driver PMOS Output Disconnect

The low-noise boost converter of the LT3498 features a PMOS output disconnect switch. This PMOS switch is

continued on page 38

Light Up 12 LEDs from a Single-Cell Li-Ion Battery via Highly Integrated 3mm × 2mm Dual-LED-String Driver

by Ben Chan

Introduction

The LT3497 is a dual step-up converter capable of driving up to 12 white LEDs from a single-cell Li-Ion input. The device is capable of driving asymmetric LED strings with independent dimming and shutdown control, perfect for driving backlight circuits in battery-powered portable devices, such as cellular phones, MP3 players, PDAs, digital cameras, and portable GPS devices.

The LT3497 directly regulates LED current, providing consistent brightness for all LEDs regardless of variations in their forward voltage drop. Important features including internal compensation, open-LED protection, DC/PWM dimming control, a 35V power switch and a 35V Schottky diode are all integrated into the part, making the LT3497 LED driver an ideal solution for space-constrained portable devices. In addition, the 2.3MHz switching frequency allows the use of tiny inductors and capacitors. Figure 1 shows a typical 12-white-LED application. Figure 2 shows the efficiency of the circuit.

Features

High Side Sense

The LT3497 features a unique high side LED current sense that enables the part to function as a 1-wire current source—the cathode side of the bottom LED in the string can be returned to ground anywhere, allowing a simple 1-wire LED connection. Traditional LED drivers use a grounded resistor to sense LED current requiring a 2-wire connection to the LED string. High side sense moves the sense resistor to the top of the LED string. In addition, high side sense allows the LT3497 to operate in unique applications (Buck-Mode

The LT3497 features a unique high side LED current sense that enables the part to function as a 1-wire current source—the cathode side of the bottom LED in the string can be returned to ground anywhere, allowing a simple 1-wire LED connection.

or Buck-Boost Mode) where traditional LED drivers cannot be used.

Dimming & Shutdown Control

The LT3497 features single pin shutdown and dimming control for each converter. The LED current in the two drivers can be set independently by modulating the CTRL1 and CTRL2 pins. There are three different types of dimming methods: DC voltage dimming, filtered PWM signal dimming and direct PWM dimming.

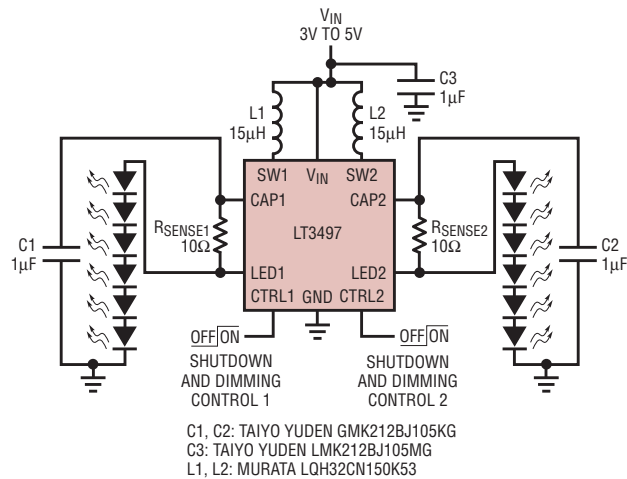

Figure 1. Li-Ion powered driver for twelve white LEDs

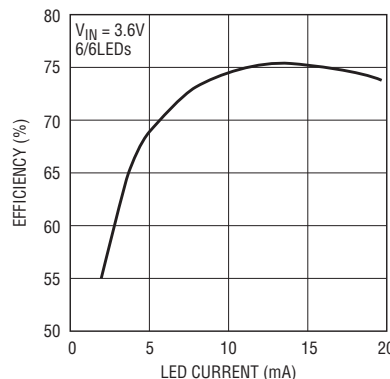

Figure 2. Efficiency of the circuit in Figure 1

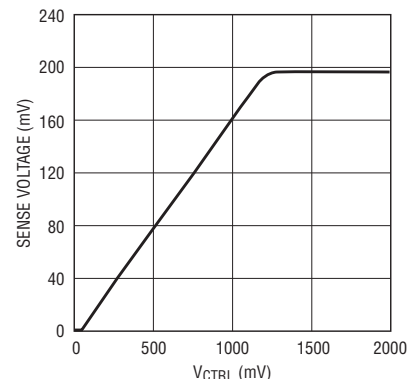

Figure 3. LED sense voltage versus CTRL pin voltage

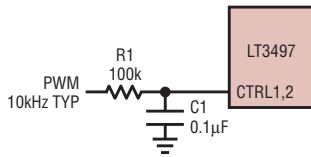

Figure 4. Filtered PWM Dimming

The LED currents are proportional to the DC voltages at the CTRL1 and CTRL2 pins, so DC voltage dimming is achieved by reducing the voltage on the CTRL pin. The dimming range of the part extends from 1.5V at the CTRL pin for full LED current down to 100mV. The CTRL pin directly controls the regulated sense voltage across the sense resistor that sets the LED current (see Figure 3).

Filtered PWM dimming works similarly to DC voltage dimming except that the DC voltage input to the CTRL pins comes from an RC-filtered PWM signal. The corner frequency of the R1 and C1 should be much lower than the frequency of the PWM signal for proper filtering. Filtered PWM dimming is shown in Figure 4.

Direct PWM dimming is typically used because it achieves a much wider dimming range compared to using a filtered PWM or a DC voltage. Direct PWM dimming uses a MOSFET in series with the LED string to quickly connect and disconnect the LED string. Figure 5 displays direct PWM dimming in a Li-Ion to a 4-and-4 white LED application. A PWM signal is applied to the CTRL pin and MOSFET where the PWM signal controls both

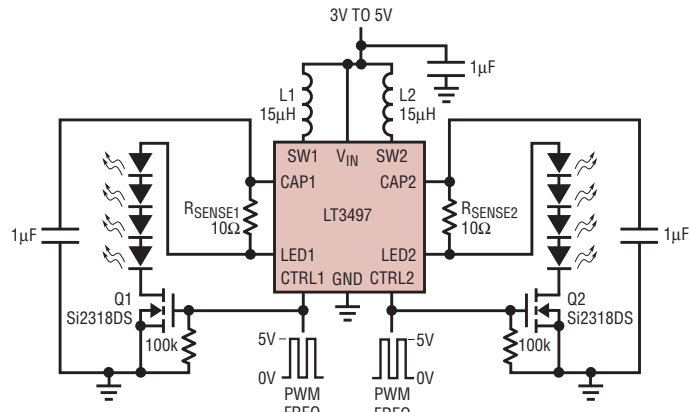

Figure 5. Li-Ion to eight white LEDs with direct PWM dimming.

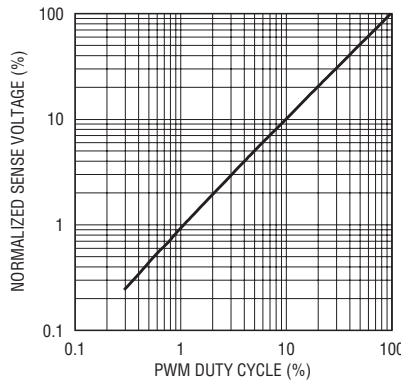

Figure 6. Linearity of PWM Dimming of Figure 5 at 100Hz

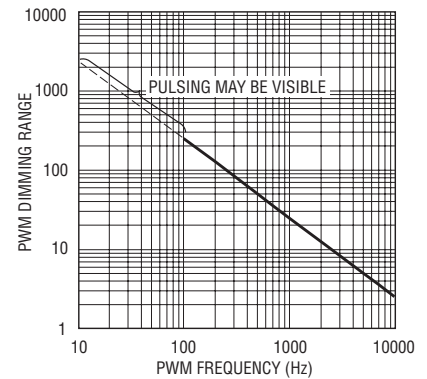

Figure 7. Dimming Ratio Range vs Frequency

the turn-on and turn-off of the part. Figure 6 shows the linearity of PWM dimming. The available dimming range depends on the settling time of the application and the PWM frequency used. The application in Figure 5 achieves a dimming range of 250:1 using a 100Hz PWM frequency. Figure 7 shows the

available dimming ranges for different PWM frequencies.

Applications

Li-Ion Powered Driver for 12 White LEDs

Figure 1 highlights the LT3497's impressive input and output voltage range. This circuit is capable of driving two strings of six LEDs each with 20mA of constant current. As shown

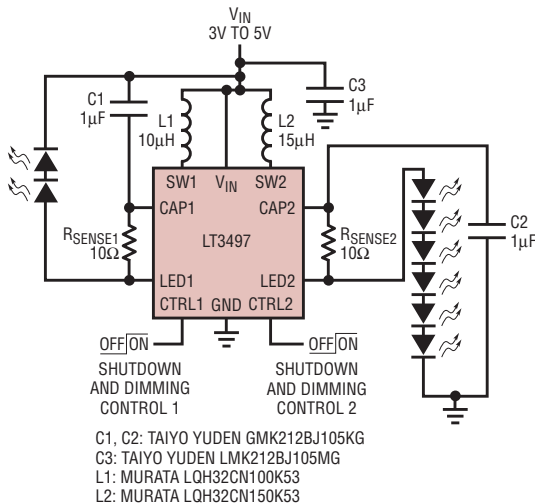

Figure 8. Li-Ion to a 2-LED and 6-LED Display

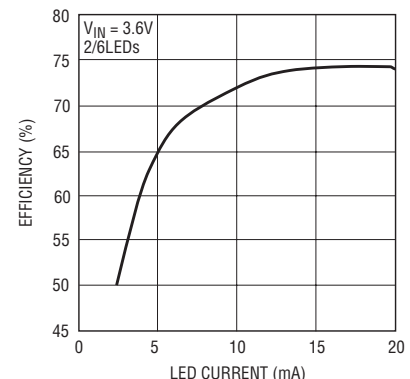

Figure 9. Efficiency of the circuit in Figure 8

in Figure 1, the circuit works from a single Li-Ion (3V) battery or 5V wall adapter. Figure 2 shows efficiency with a 3.6V input.

Li-Ion to a 2-LED and 6-LED Display

Figure 8 (Buck-Boost/Boost configuration) shows a white LED driver used to backlight two displays: a 6-LED main and a 2-LED sub display. This design generates a constant 20mA in

each white LED string from a Li-Ion (3V~4.2V) or 5V adapter input. Two independent dimming and shutdown controls (CTRL1 and CTRL2) simplify power management and extend battery life. Figure 9 shows the efficiency of the circuit.

Conclusion

The LT3497 is a dual channel white LED driver capable of driving up to 12 white LEDs from a single cell Li-Ion

input. The device features 35V internal power switches, internal Schottky diodes, DC or PWM dimming control, open LED protection and optimized internal compensation. The LT3497 is an ideal solution for a wide range of applications including multipanel LCD backlighting, camera flash or space constrained portable applications such as cellular phones, MP3 players, PDAs and digital cameras. 

LT3080, continued from page 5

pin serving as ballast to equalize the currents. PC trace resistance in milliohms/inch is shown in Table 3. Only a tiny area is needed for ballasting.

Figure 6 shows two devices with a small 10mΩ ballast resistor, which at full output current gives better than 80% equalized sharing of the current. The external resistance of 10mΩ (5mΩ for the two devices in parallel) only adds about 10mV of output regulation drop at an output of 2A. Even with the 1V output, this only adds 1% to the regulation.

Thermal Performance

Two LT3080 3mm × 3mm QFN devices are mounted on a double sided PC board. They are placed approximately 1.5 inches apart and the board is mounted vertically for convection cooling. Two tests were set up to measure the cooling performance and current sharing of these devices.

The first test was done with approximately 0.7V input-to-output differential and a 1A load per device. This setup produced 700mW dissipation in each device and a 2A output current. The temperature rise above ambient is approximately 28°C and both devices were within ±1°C of each other. Both the thermal and electrical sharing of these devices is excellent. The thermograph in Figure 7 shows the temperature distribution between these devices, where the PC board reaches ambient within about 0.5in from the devices.

Figure 8 shows what happens when the power is increased to 1.7V across each device. This produces 1.7W dis-

sipation in each device and a device temperature of about 90°C, about 65°C above ambient. Again, the temperature matching between the devices is within 2°C, showing excellent tracking between the devices. The board temperature drops to about 40°C within 0.75 inches of each device.

While 95°C is an acceptable operating temperature for these devices, this rise is in a 25°C ambient environment. For higher ambient temperatures, the temperature rise must be controlled to prevent the device temperature from exceeding 125°C. A 3-meter-per-second airflow across the devices decreases the device temperature by about 20°C, providing a margin

for higher operating ambient temperatures. Also, this example is for a 2-layer board. A 4-layer board would provide better power dissipation.

Conclusion

The LT3080's breakthrough design and high performance DC characteristics allows it to be paralleled for high current all-surface-mount applications. It is also adjustable to zero output, an impossible feat with a traditional 3-terminal adjustable linear regulator. It is optimized for new circuit applications and all-surface-mount system assembly techniques—especially high performance, high density circuit boards. 

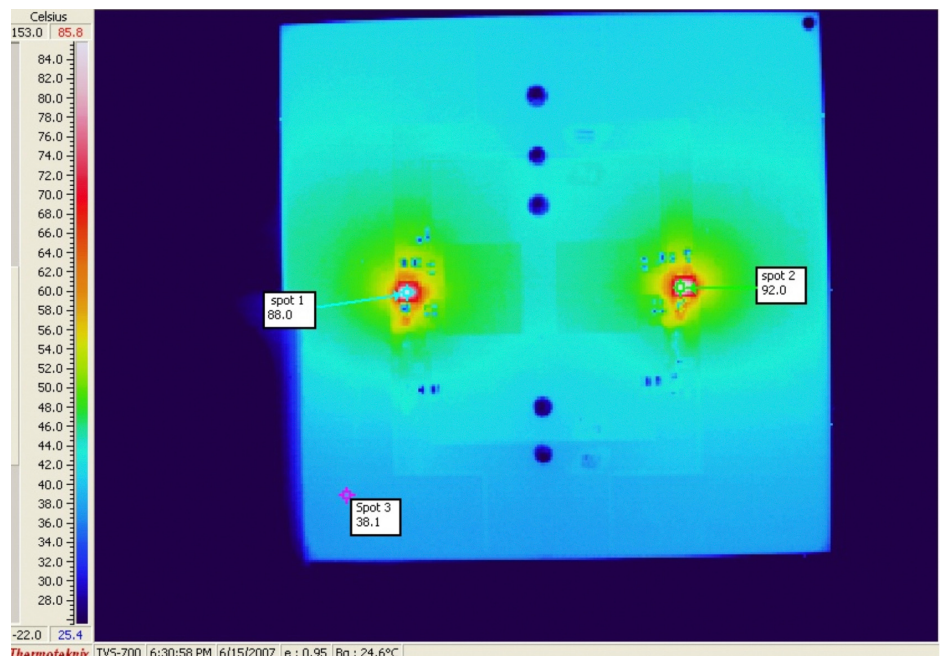

Figure 8. Thermograph shows a 65°C rise for two regulators, each dissipating 1.7W from a 1.7V input-to-output differential at 2A load.

Low Offset 2-Wire Bus Buffer Provides Capacitance Buffering, Stuck Bus Recovery, and Tolerates High V_{OL}

by John Ziegler

Introduction

High availability computing, networking and data storage systems employ system management buses such as I²C or SMBus to monitor system health. These simple serial buses allow system controllers to monitor parameters such as temperature and voltage, read vital product information from individual cards, and make changes to the system, such as controlling fan speed. As these systems increase in complexity, several implementation issues arise with the system management bus.

First, each additional device on the bus adds a capacitive load. The bus capacitance of a large system makes meeting rise time specifications very difficult. While a strong pull-up resistor can reduce the rise time, the penalty is increased V_{OL} and decreased noise margin. Second, some devices that can communicate via I²C or SMBus have a V_{OL} that is near or above the maximum allowed by the standards. Third, power cannot be cycled whenever a new card is added to the system. Finally, since any device can hold the bus low, each additional device increases the chance of a stuck bus caused by a single confused device.

The LTC4309 solves all of these problems by acting as a buffer between two physically separate 2-wire buses. The input side of the LTC4309, SDAIN and SCLIN, connects to one 2-wire bus (backplane), while the output side, SDAOUT and SCLOUT, connects to the other bus (I/O card). The LTC4309 provides bidirectional buffering, keeping the backplane and card capacitances isolated from each other.

The LTC4309's low, pull-up independent offset voltage allows multiple devices to be put in series while meeting V_{OL} and maintaining noise margin.

The LTC4309 solves many I²C and SMBus problems by acting as a buffer between two physically separate 2-wire buses.

The input side of the LTC4309, SDAIN and SCLIN, connects to one 2-wire bus (backplane) while the output side, SDAOUT and SCLOUT, connects to the other bus (I/O card). The LTC4309 provides bidirectional buffering, keeping the backplane and card capacitances isolated from each other.

A large system can be broken into many smaller buses by inserting LTC4309s throughout the system, reducing the capacitance of each electrically isolated bus. The LTC4309's rise time accelerators help to further reduce the rise time.

The LTC4309 has connection circuitry that connects and passes a logic low even if the input voltage is above the bus specification V_{OL} . The low, pull-up independent offset reduces the impact to the V_{OL} of buffering the bus.

Since the LTC4309's SDA and SCL pins are high impedance when inactive or powered down, the LTC4309 can be inserted into a live bus without corrupting the bus. The LTC4309's capacitance buffering feature also isolates the capacitance of the card from the live bus during, and after, insertion.

Finally, the LTC4309's stuck bus detection circuitry can detect when

a bus is stuck in a low condition and disconnect the stuck portion of the system while attempting to recover the stuck bus.

Circuit Operation

Start Up

A block diagram of the LTC4309 is shown in Figure 1. When the LTC4309 first receives power on its V_{CC} pin, either during power up or live insertion, it starts in an undervoltage lockout (UVLO) state, ignoring any activity on the SDA or SCL pins until V_{CC} rises above 2.0V (typ). This is to ensure that the LTC4309 does not try to function until it has enough voltage to do so. During this time, the 1V precharge circuitry is active and forces 1V through 100k nominal resistors to minimize the worst-case voltage differential these pins see at the moment of connection, thus minimizing the disturbance caused by the I/O card.

Once the LTC4309 comes out of UVLO and the ENABLE input is high, it monitors both the input and output sides for either a stop bit or bus idle condition to indicate the completion of data transactions. When transactions on both sides of the LTC4309 are complete, the back-to-back buffers shown in Figure 1 (referred to below as "connection circuitry") are activated, joining the SDA and SCL buses on the input side with those on the output. Once the connection is made, the READY pin is released, allowing it to pull up and signal that the connection is complete. READY remains high as long as the connection circuitry is active. If the ENABLE pin is grounded, the LTC4309 does not connect and I/Os remain in a high impedance state until ENABLE is pulled high.

Connection Circuitry

When the connection circuitry is activated, the functionality of the SDAIN and SDAOUT pins, as well as SCLIN and SCLOUT, are identical. When an external device pulls any SDA or SCL pin below a threshold of 1.65V (for $V_{CC} > 2.9V$) or 1.35V (for $V_{CC} < 2.9V$) the LTC4309 detects a low and pulls the other side down to a voltage that is 60mV above the forced voltage. This low offset is practically independent of bus voltage level and pull-up resistance. The LTC4309 remains connected until the input and output are above 0.6V and it senses a rising edge on both the input and output or

until one side is above the $0.45 \cdot V_{CC}$ connection threshold. The LTC4309's connection circuitry ensures that the input and output enter a logic high state only when all devices on both sides of the LTC4309 have released the bus and the pull-ups have pulled the bus high. This important feature ensures that clock stretching, clock arbitration and the acknowledge protocol always work, regardless of how the devices in the system are connected to the LTC4309.

Another key feature of the connection circuitry is that, while it joins the two buses together, it still maintains electrical isolation between them, thus

providing capacitance buffering for both sides. With the LTC4309's low offset and tolerance to devices having high V_{OL} , multiple devices can be cascaded on a single bus. This allows larger systems to be divided into many smaller, less capacitive and therefore faster buses. The LTC4309 is capable of driving capacitive loads ranging from 0pF to more than 1000pF on all of its data and clock pins.

Stuck Bus Detection and Recovery

Slave devices on a bus use the clock signal to sample the data. Occasionally, devices become confused and get stuck in a low state, causing a "stuck"

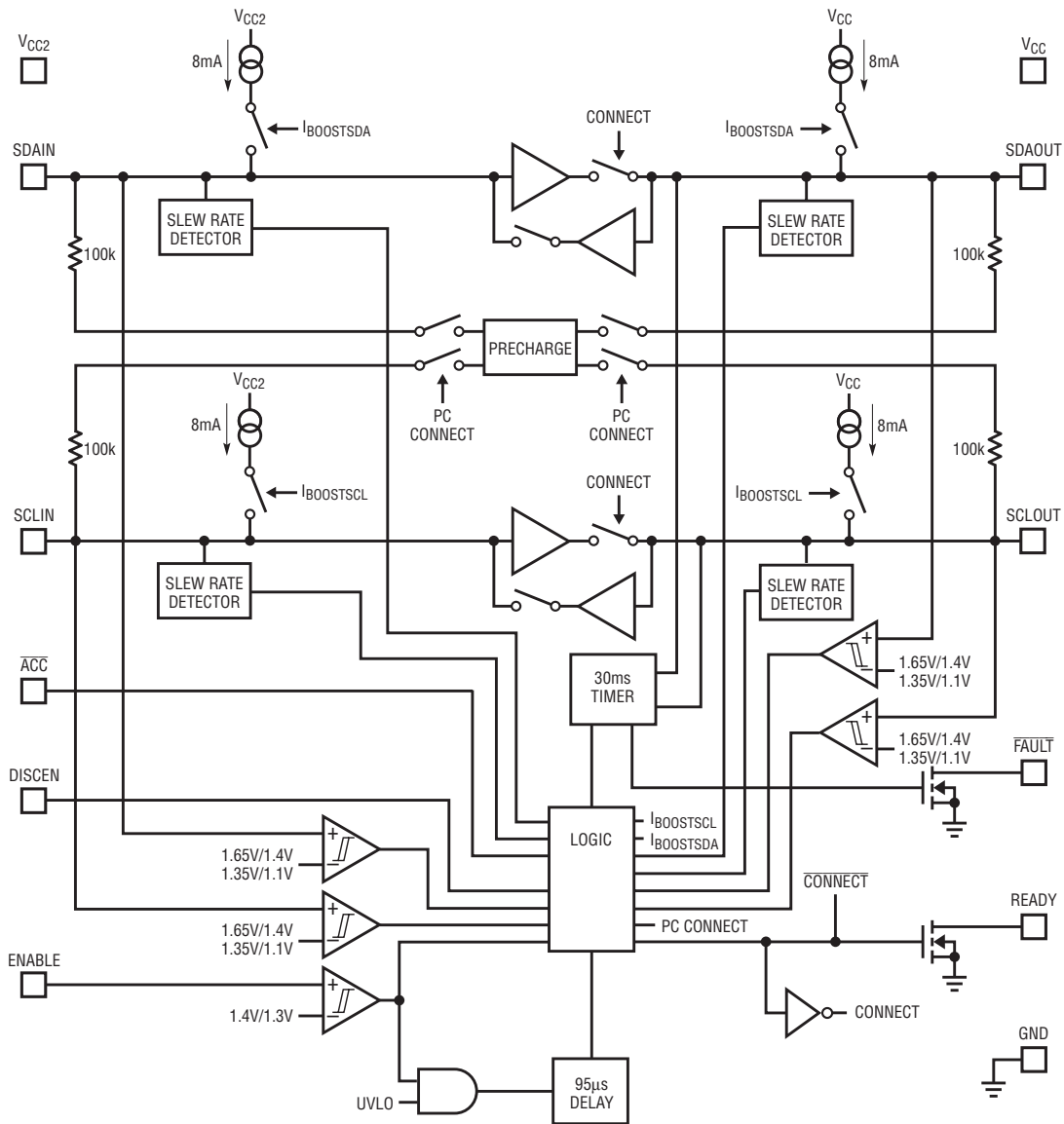

Figure 1. Block diagram of LTC4309. The input side of the LTC4309, SDAIN and SCLIN, connects to one 2-wire bus (backplane), while the output side, SDAOUT and SCLOUT, connects to the other bus (I/O card). The LTC4309 provides bidirectional buffering, keeping the backplane and card capacitances isolated from each other.

bus. The LTC4309 monitors both the data and clock buses independently for a stuck bus condition. If either data or clock is in a low state for more than 30ms, the LTC4309 determines that the bus is “stuck.” The LTC4309 signals a fault condition by pulling the $\overline{\text{FAULT}}$ and $\overline{\text{READY}}$ pins low and disables the connection circuitry, disconnecting the stuck bus and freeing the portion of the bus that is not stuck. At this time, the LTC4309 attempts to free the stuck bus by generating up to 16 clock pulses on SCLOUT . Once the 16 pulses are completed, or the clock pulses terminate due to the bus becoming unstuck, a stop bit is generated to clear the bus for further communication. If a master wants to force reconnection of the bus after the LTC4309 has disconnected the bus due to a fault condition, the master can pull the $\overline{\text{ENABLE}}$ pin low and immediately high again. This resets the 30ms timer and forces the LTC4309 to reconnect.

The LTC4309’s stuck bus recovery feature is illustrated in Figure 2. After SDAOUT has been held low for 30ms,

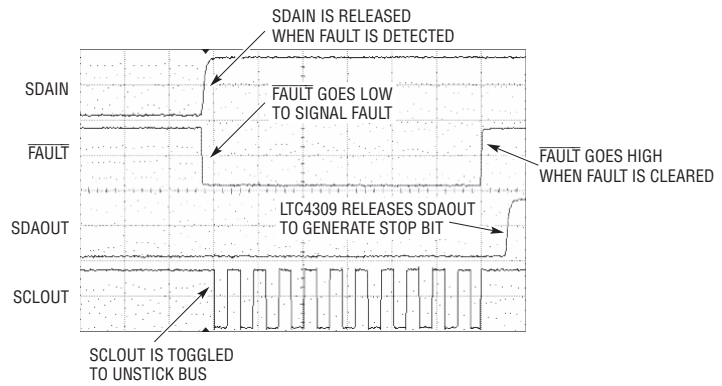

Figure 2. The stuck bus recovery feature of the LTC4309 disconnects stuck buses and uses auto clocking to recover the stuck bus.

the LTC4309 detects the stuck bus. The LTC4309 pulls the $\overline{\text{FAULT}}$ pin low, and releases the SDAIN bus. The SCLOUT pin is then toggled at 8.5kHz in an attempt to free the bus. In this example, after 11 clock edges the bus becomes unstuck and the $\overline{\text{FAULT}}$ pin is released. Note that SDAOUT temporarily goes high at the same time that $\overline{\text{FAULT}}$ goes high, but this is not visible in the figure due to the time scale and due to the LTC4309 quickly pulling SDAOUT back low so that it can generate a Stop Bit on the

bus. The LTC4309 holds SDAOUT low for 125 μs , then releases SDAOUT to generate the Stop Bit.

If automatic disconnection is not desired, this feature can be disabled by connecting the $\overline{\text{DISCEN}}$ pin to GND. The LTC4309 still monitors both sides for a stuck bus condition and pulls $\overline{\text{FAULT}}$ low if a fault occurs, but does not disconnect the bus or attempt to free the stuck bus. A master can disconnect the stuck bus manually by pulling the LTC4309’s $\overline{\text{ENABLE}}$ pin low. This forces the connection

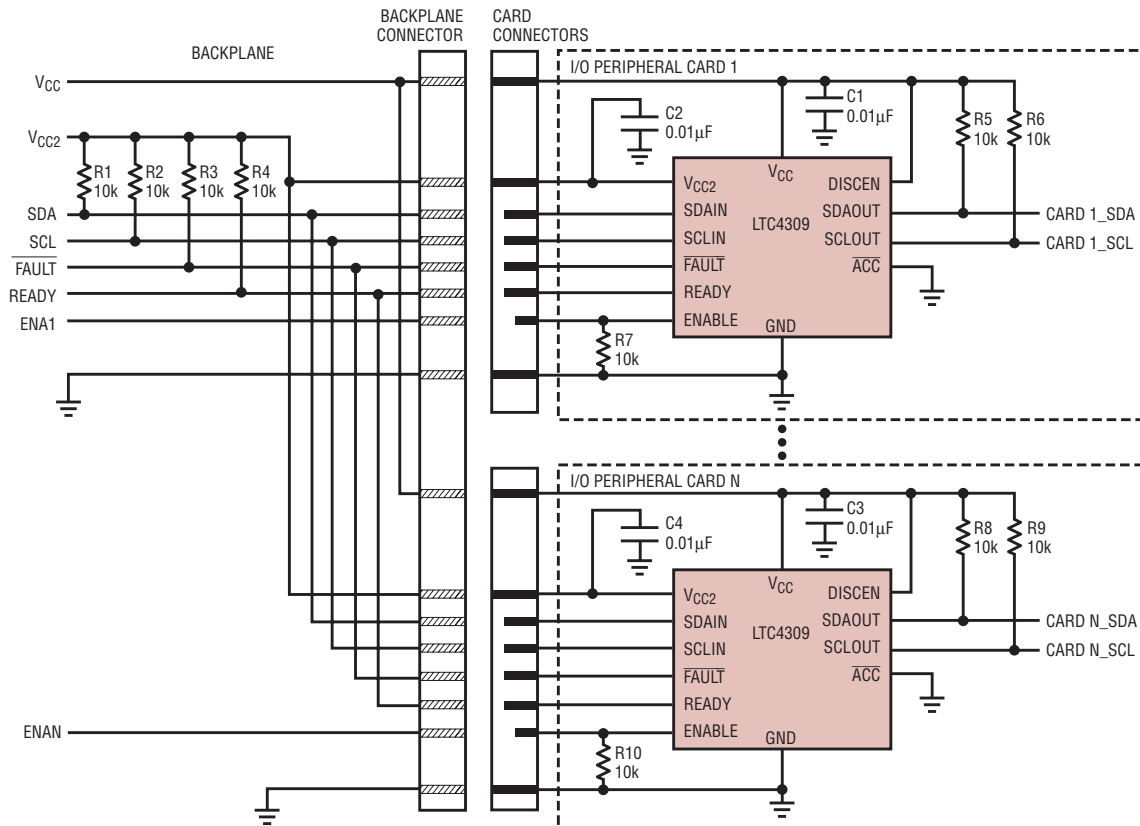

Figure 3. The LTC4309 in a live insertion and capacitance buffering application

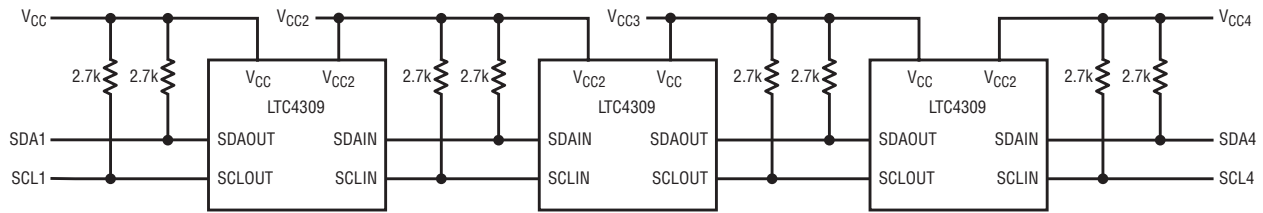

Figure 4. The LTC4309 provides level translating, and allows cascading of multiple buffers while meeting system V_{OL} requirements.

circuitry to disconnect the inputs from the outputs, and put the I/O pins in a high impedance state. Once the master has cleared the stuck bus, the LTC4309 ENABLE pin can be pulled high. When the bus is idle, the LTC4309 reconnects the input to the output as described previously.

Rise Time Accelerators

The \overline{ACC} pin controls the state of the rise time accelerators. If the \overline{ACC} pin is tied to GND, all four accelerators are activated. To disable the input side accelerators only, tie the \overline{ACC} and V_{CC2} pins to GND. Connect the \overline{ACC} pin to V_{CC} to disable all four rise time accelerators. When activated, the rise time accelerators switch in 8mA of slew limited pull-up current at $V_{CC} = 3.3V$ during bus rising edges to quickly slew the SDA and SCL lines once their DC voltages exceed 0.8V and the initial rise rate on the pin exceeds $0.8V/\mu s$. The slew limiting is achieved by monitoring the rising edge; if the edge is rising faster than $1V/10ns$, the pull-up current is reduced. This helps prevent signal integrity issues in lightly loaded systems where a strong pull-up could make the rising edge fast enough to create transmission line reflections on the bus.

Live Insertion and Removal, and Capacitance Buffering Application

The application shown in Figure 3 highlights the live insertion/removal and the capacitance buffering features of the LTC4309. Assuming that a staggered connector is available, make ground, V_{CC} and V_{CC2} the longest pins to guarantee that SDAIN and SCLIN receive the 1V pre-charge voltage before they connect. Make SDAIN and SCLIN medium length pins to ensure that they are firmly connected

while ENABLE is low. Make ENABLE the shortest pin and connect a weak resistor from ENABLE to ground on the I/O card. This ensures that the LTC4309 remains in a high impedance state while SDAIN and SCLIN are making connection during live insertion. During live removal, having ENABLE disconnect first ensures that the LTC4309 enters a high impedance state in a controlled manner before SDAIN and SCLIN disconnect.

Note that if an I/O card were plugged directly into the backplane, the card capacitance would add directly to the backplane capacitance, making rise and fall time requirements difficult to meet. Inserting a LTC4309 on the edge of the card, however, isolates the card capacitance from the backplane. The LTC4309 drives the capacitance of everything on the card, and the backplane must drive only the capacitance of the LTC4309. As more I/O cards are added and the system grows, placing a LTC4309 on the edge of each card breaks what would be one large, unmanageable bus into several manageable segments, while still allowing all segments to be active at the same time. If breaking the bus up further is desired, the LTC4309's low offset and high V_{OL} tolerance allows cascading of multiple devices. Moreover, the LTC4309's rise time accelerators provide strong pull-up currents during bus rising edges, so that even heavily loaded bus lines meet system rise time requirements with ease.

Level Translator and Cascading Applications

The LTC4309's very low offset, typically 60mV, allows cascading of multiple devices while still meeting V_{OL} specifications. Figure 4 illustrates an application where three LTC4309s

have been used to break a bus into four isolated buses. The total offset of the cascaded devices is approximately 180mV. This feature can be used in conjunction with the level translating feature of the LTC4309 and each isolated section of the bus can operate off a different supply voltage. The LTC4309 functions for voltages ranging from 2.3V to 5.5V on V_{CC} and 1.8V to 5.5V on V_{CC2} .

Simplified 8-Pin Option in the LTC4307

The LTC4307 is a simplified 8-pin version of the LTC4309. For the LTC4307, the DISCEN, \overline{ACC} , \overline{FAULT} and V_{CC2} pins are removed. The rise time accelerators and stuck bus recovery are always enabled. Since there is no \overline{FAULT} pin, the READY pin should be monitored to determine if a fault condition occurs.

Conclusion

The LTC4309 low offset buffer allows I/O cards to be hot-plugged into live systems and breaks one large capacitive bus into several smaller ones, while still passing the SDA and SCL signals to every device in the system. The low, pull-up independent offset allows cascading of multiple devices, breaking the bus into smaller, less capacitive sections. Slew limited rise time accelerators further decrease the rise time and allow the bus to operate at higher frequencies, or with better data integrity. Stuck bus recovery helps maintain system integrity by detecting and clearing stuck buses. The LTC4309's tolerance to high V_{OL} allows capacitance buffering on buses with other devices that may not meet V_{OL} specifications. With these features, the LTC4309 simplifies the design process of complex 2-wire bus systems. 

Compact and Versatile Monolithic Synchronous Buck Regulators Deliver 1.25A in Tiny TSOT23, DFN and MS10 Packages

by Jaime Tseng

Introduction

To meet industry demands to squeeze more power from smaller packages the LTC3564 monolithic synchronous buck regulator provides 1.25A from a tiny TSOT23-5 package. Its siblings, the LTC3565 and LTC3411A, also 1.25A monolithic synchronous bucks, come in 10-lead 3mm × 3mm DFN and MS10 packages. The LTC3564's internal switching frequency is set at a fixed 2.25MHz to allow the use of tiny inductors and ceramic output capacitors. Switching at this high frequency does not compromise efficiency. In Burst Mode operation, the LTC3564 only needs 20µA of quiescent current and <1µA in shutdown. The internal 150mΩ power MOSFETs keep the power dissipation low and efficiencies as high as 94% at maximum load current.

Adding More Options

The additional pins of the LTC3565 and LTC3411A give them a versatility edge over the LTC3564. Both parts can program their internal frequency, synchronize to an external clock, select the mode of operation among Burst Mode operation, pulse-skipping, or forced continuous mode, and provide a PGOOD indicator output. For noise-sensitive applications, pulse-skipping mode decreases the output ripple noise at low currents. Although not as efficient as Burst Mode operation at light load, pulse-skipping mode still provides high efficiency for moderate loads. In forced continuous

mode a steady operating frequency is maintained at all load conditions, making it easier to reduce noise and RF interference—important for some applications. In order to squeeze into a TSOT23-5 package, the LTC3564 forgoes a few features such as PGOOD, the ability to adjust the switching frequency and the mode select. The frequency and mode of operation are internally set at 2.25MHz and Burst Mode operation respectively.

All three devices employ a constant frequency, current mode architecture that operates from an input voltage range of 2.5V to 5.5V and provides an

DESIGN IDEAS

Compact and Versatile Monolithic Synchronous Buck Regulators Deliver 1.25A in Tiny TSOT23, DFN and MS10 Packages.....32
Jaime Tseng

Single-IC Converter Operates Buck and Boost to Provide an Output that is Within the Input Voltage Range.....34
David Burgoon

Feature-Rich Monolithic Triple Buck Regulator Supplies Up To 2.4A from a 3mm × 3mm Package35
Kevin Soch

Single-Wire Camera LED Charge Pump Allows Multiple Output Current Levels With Single-Resistor Programmability37
Mohammed H. Jafri

Compact Controller is a Basic Building Block for Wide Array of DC/DC Conversion Solutions39
Victor Khasiev and Hong Ren

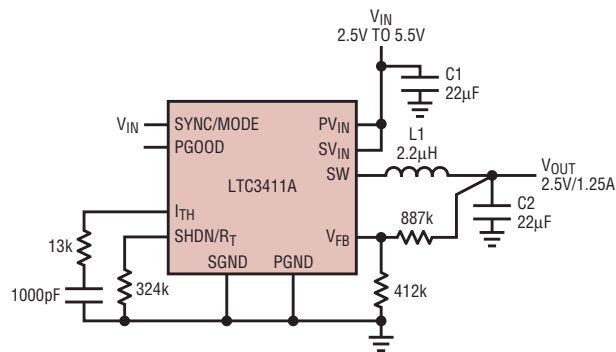

Figure 1. Battery to 2.5V at 1.2A application of the LTC3411A

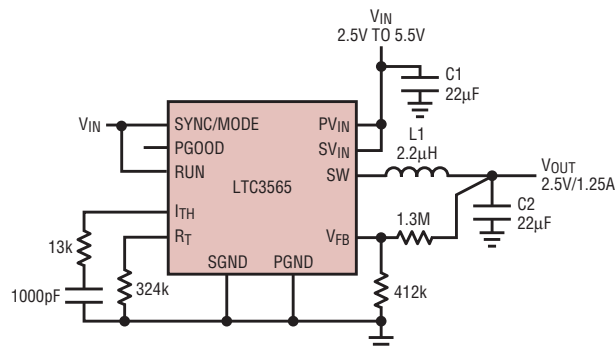

Figure 2. Battery to 1.2V at 1.2A application of the LTC3565

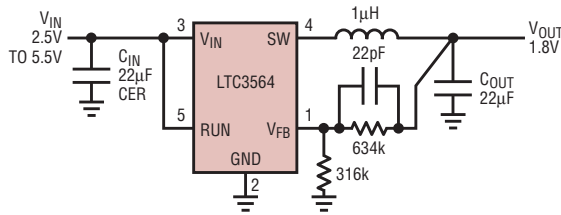

Figure 3. Battery to 1.2V at 1.2A application of the LTC3564

adjustable regulated output voltage down to 0.6V (0.8V for LTC3411A), which make them ideal for single-cell Li-Ion or 3-cell NiCd and NiMH applications. The 100% duty cycle capability for low dropout allows maximum energy to be extracted from the battery. In dropout, the output voltage is determined by the input voltage minus the voltage drop across the internal P-channel MOSFET and the inductor resistance.

The switching frequency of the LTC3565 and LTC3411A can be set between 400kHz and 4MHz with an external resistor or synchronized to an external clock. The LTC3411A is a drop-in replacement for the popular LTC3411, but with improved efficiency at higher V_{IN} and improved response to fault conditions.

Adaptive Current Reversal Comparator

In each of the parts, a patent pending adaptive current reversal comparator monitors the current reversal across the synchronous switch. In discontinuous mode, to emulate the behavior of an ideal diode, the synchronous switch turns on when the inductor current is positive and turns off when the inductor current is negative. Because the comparator has a finite propagation

delay, the inductor current trip point is offset before zero. This offset depends on the output voltage of the regulator and the inductor value used on the board. In the LTC3564, LTC3565 and

The LTC3564, LTC3565 and LTC3411A employ a constant frequency, current mode architecture that operates from an input voltage range of 2.5V to 5.5V and provides an adjustable regulated output voltage down to 0.6V (0.8V for LTC3411A), which make them ideal for single cell Li-Ion or 3-cell NiCd and NiMH applications.

LTC3411A, the offset of the current reversal comparator is automatically adjusted for any output voltage and inductor value to ensure the synchronous switch is always turned off at the right inductor current value.

Fault Protection

All three parts are protected against output short-circuit and output over-dissipation conditions. The output can

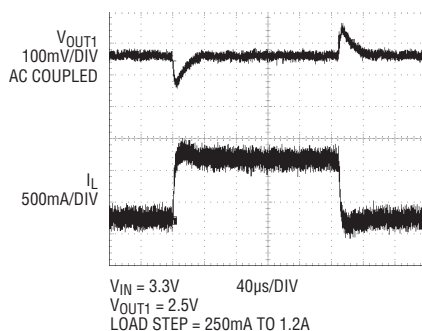

Figure 5. Load step response

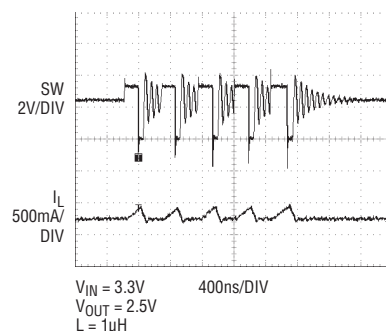

Figure 6. Operating waveforms

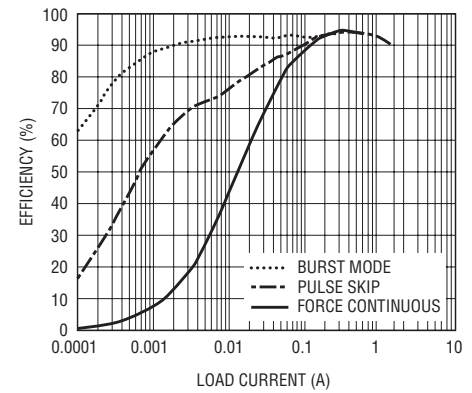



Figure 4. Efficiency vs load current for the circuit of Figure 1 in various operating modes

be shorted to ground or V_{IN} in any mode without fear of damage. When a V_{OUT} short to V_{IN} is removed the output returns immediately to its regulated output voltage if forced continuous mode is selected. This allows the use in a pre-biased application where the output is held at higher than the regulated output when the part is shutdown. When there is a power over-dissipation condition and the junction temperature reaches 160°C, the thermal protection circuit turns off the power switches. Normal operation does not resume until the part cools off and the junction temperature drops back to 150°C.

Conclusion

Three monolithic synchronous step-down voltage regulators provide up to 1.25A of output current in a tiny footprint. The LTC3564, LTC3565 and LTC3411A also offer high switching frequency, high efficiency and a number of versatile features that make them an excellent choice for portable applications. 

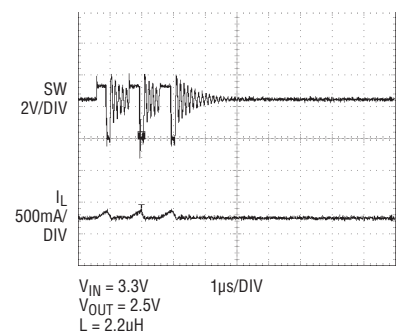

Figure 7. Operating waveforms

Single-IC Converter Operates Buck and Boost to Provide an Output that is Within the Input Voltage Range

by David Burgoon

Introduction

Generating an output voltage that is always above or below the input voltage range can easily be handled by conventional boost or buck regulators, respectively. However, when the output voltage is *within* the input voltage range, as in many Li-Ion battery powered applications requiring a 3V or 3.3V output, conventional designs fall short, suffering variously from low efficiency, complex magnetics, polarity inversion and circuit complexity. The LTC3785 buck-boost controller facilitates a simple, efficient, low parts-count, single-converter solution that is easy to implement and does not have any of the drawbacks associated with conventional circuits.

3.3V, 3A Converter Operates from 2.7V-10V Source

Figure 1 shows a synchronous, 4-switch, buck-boost design that provides a 3.3V, 3A output from a 2.7V-10V input—perfect for a Li-Ion and/or loosely regulated wall adapter input. The controller provides short-circuit protection, offering a choice of burp-mode or latch-off operation for severe overload faults. Other features include soft-start, overvoltage protec-

tion (OVP) and a 2.7V-10V output range.

The circuit produces seamless operation throughout the input voltage range, operating as a synchronous buck converter, synchronous boost

converter, or a combination of the two through the transition region. At input voltages well above the output, the converter operates in buck mode. Switches Q1A and Q1B commutate the input voltage, and Q2A stays

continued on page 36

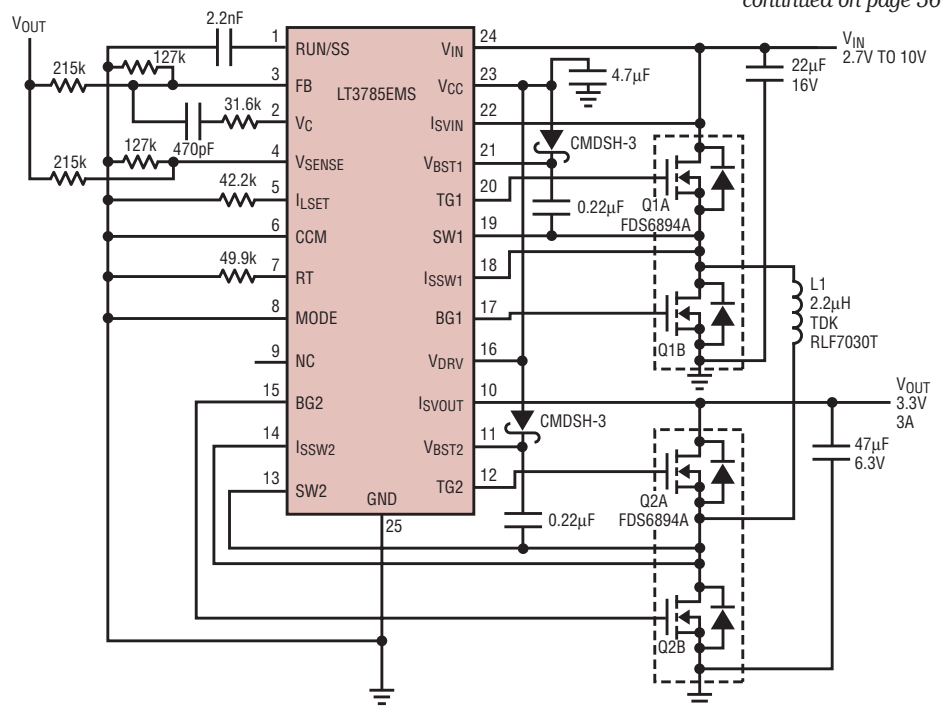

Figure 1. Schematic of buck-boost converter using LTC3785 to provide 3.3V at 3A out from a 2.7V-10V source

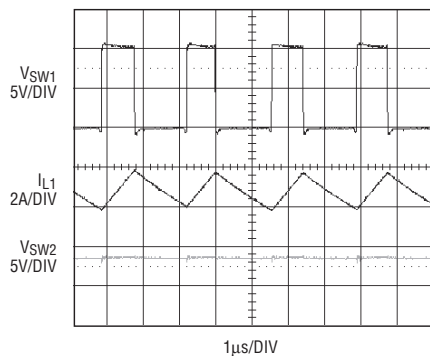

Figure 2. Input-side and output-side switch waveforms along with inductor current for buck mode (10VIN)

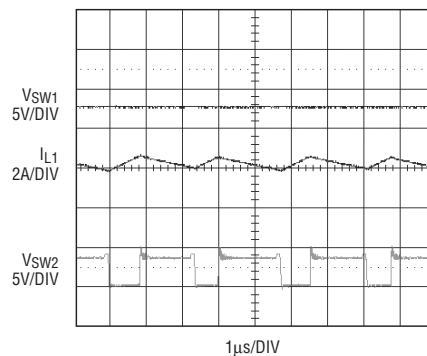

Figure 3. Input-side and output-side switch waveforms along with inductor current for boost mode (2.7VIN)

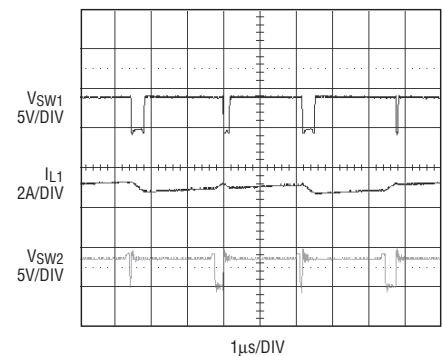

Figure 4. Input-side and output-side switch waveforms along with inductor current for buck-boost mode (3.8VIN)

Feature-Rich Monolithic Triple Buck Regulator Supplies up to 2.4A from a 3mm × 3mm Package

by Kevin Soch

Introduction

The triple output LTC3545 is a monolithic synchronous buck regulator capable of supplying three independent voltage supply rails, each with maximum output current of 800mA and peak efficiency over 90%. The 3mm × 3mm QFN package and default internal 2.25MHz switching frequency allow for a simple and compact multiple power supply solution. The input voltage range of 2.25V to 5.5V is perfect for batteries and the output voltage is resistor programmable down to 0.6V. Features include selectable high efficiency Burst Mode operation or low ripple pulse-skipping mode, soft-start, power sequencing, and the option for externally driven 1.0MHz to 3.0MHz switching frequency.

High Level of Integration

Many of the external components required to operate a typical switching regulator have been integrated into the LTC3545. Internal loop compensation

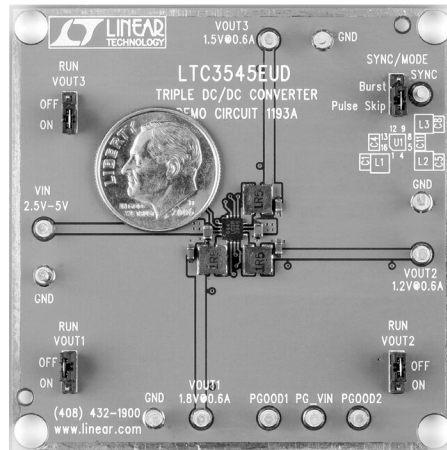

Figure 1. The LTC3545 is a compact solution to the problem of multiple voltage supplies.

eliminates the need for external compensation resistors and capacitors, integrated synchronous switches eliminate the need for external Schottky diodes, and an integrated soft-start function eliminates the need for external capacitors or control ramps.

The placement of the package pins ensures the isolation of the sensitive feedback pins and a logical and compact board layout, particularly with respect to the power paths. Figure 1 is a photo of the LTC3545 demoboard with the power components primarily on the top. The feedback components (not shown) reside on the bottom of the board. Total circuit footprint for this board is approximately 300mm².

Power Sequencing Example

Figure 2 shows the schematic of an application providing three voltage supply rails with power sequencing. The outputs are externally programmed to 1.8V, 1.2V, and 1.5V. In this application, PGOOD1 is connected to the RUN2 pin and PGOOD2 is connected to the RUN3 pin. The power on sequence is shown in Figure 3. The soft-start feature prevents large

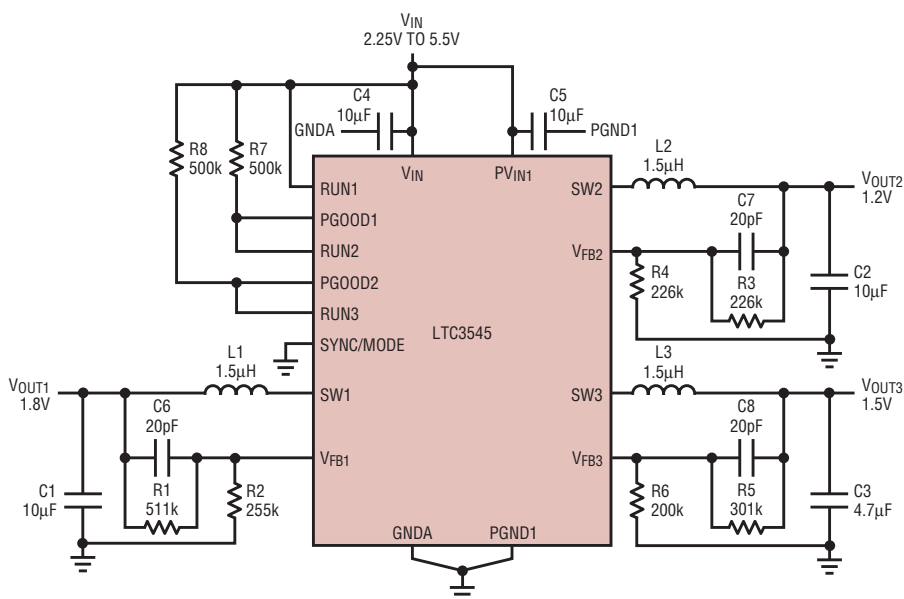

Figure 2. A high level of integration minimizes the number of necessary external components.

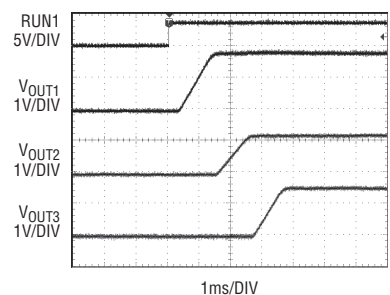

Figure 3. PGOOD pins allow simple power sequencing. Soft-start reduces inrush currents and prevents output voltage overshoot.

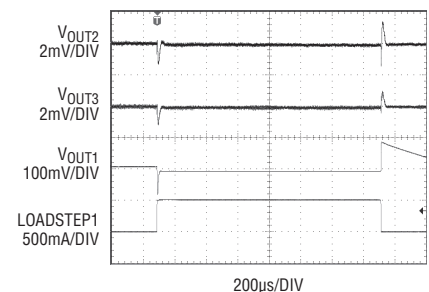

Figure 4. Channel-to-channel transient crosstalk is negligible.

inrush currents while charging the output caps during startup, as well as minimizing voltage overshoot when starting into light loads.

For those applications requiring a power good output on the third channel, the LTC3545-1 version of the part substitutes a PGOOD3 output in place of the MODE/SYNC pin. The option of an external clock is not available on this version, and the part enters Burst Mode operation at light load currents.

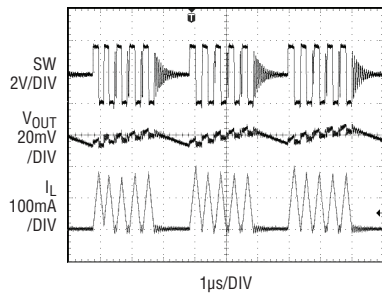

Figure 5. At low load currents, Burst Mode operation improves efficiency without degrading output voltage ripple.

Minimal Channel Crosstalk

A potential problem with multiple output regulators is the interaction between channels when one of the channels undergoes a load transient. Figure 4 shows the response on channels 2 and 3 to a 0mA to 500mA load step on channel 1. Channels 2 and 3 are each loaded at 400mA. In each case, the crosstalk is on the order of 1mV to 2mV.

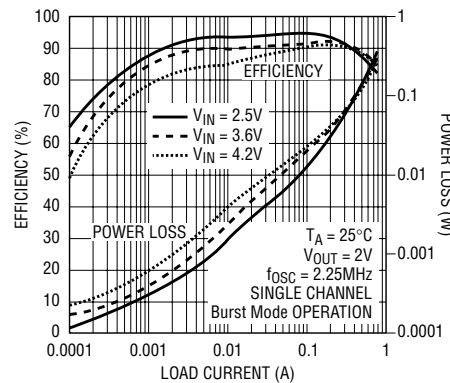

Figure 6. Burst Mode operation maintains high efficiency at low load currents.

High Efficiency with Low Ripple

At low load currents, the LTC3545 operates in either pulse-skipping mode or Burst Mode operation depending on the state of the MODE/SYNC pin. Though pulse-skipping mode exhibits lower output ripple, the ripple in Burst Mode operation is still quite low while maintaining the added advantage of better efficiency at the lightest loads. The Burst Mode operation and Burst Mode efficiency are shown in Figures 5 and 6.

Conclusion

The LTC3545 is a unique part with tremendous flexibility. It greatly simplifies system and board design where multiple voltage supply rails are needed without sacrificing the features and performance found in individual regulators. The LTC3545 is ideally suited for battery powered applications where multiple or isolated voltage rails are required and board space is at a premium. **LT**

LTC3785, continued from page 34

on, connecting L1 to the output. As the input voltage is reduced and approaches the output, the converter approaches maximum duty cycle on the input (buck) side of the bridge, and the output (boost) side of the bridge starts to switch, thus entering the buck-boost or 4-switch region of operation. As the input is reduced further, the converter enters the boost region at the minimum boost duty cycle. Switch Q1A stays on, connecting the inductor to the input, while switches Q2A and Q2B commutate the output side of the inductor between the output capacitor and ground.

In boost mode, this converter has the ability to limit input current and to shut down and disconnect the source from the output—two very desirable features that a conventional boost converter cannot provide. Figures 2, 3, and 4 show input-side and output-side switch waveforms along with inductor current for buck ($10V_{IN}$), boost ($2.7V_{IN}$), and buck-boost ($3.8V_{IN}$) modes of operation.

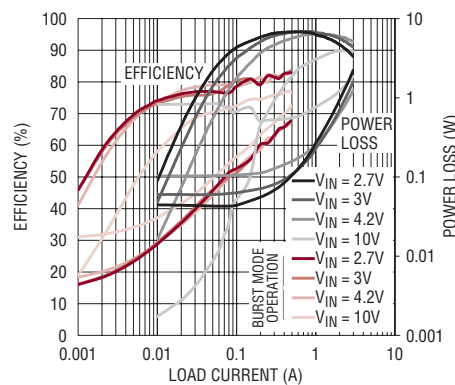

Figure 5. Efficiency in normal mode and Burst Mode operation

95% Efficiency

Figure 5 shows efficiency in both normal (not forced continuous conduction) and Burst Mode operation. Very high efficiency of 95% is achieved at typical loads. This level of performance results in part from sophisticated controller features including high side drivers for N-channel MOSFETs and $R_{DS(ON)}$ current sensing for current

limit. Even higher efficiencies are possible by using a larger inductor and better MOSFETs as they become available. Efficiency at 10V in would benefit from an inductor with a low-loss ferrite core, especially at light loads. This circuit easily fits in $0.6in^2$ with components on both sides of the board. The curves show how Burst Mode operation improves efficiency at extremely light loads, dramatically enhancing battery life in applications such as memory that must maintain housekeeping functions even when the system is turned off.

Conclusion

The LTC3785 buck-boost controller overcomes the deficiencies of traditional designs with a smooth-transition, 4-switch, single-IC solution. It is elegant in its simplicity, high in efficiency and requires only a small number of inexpensive external components. The LTC3785 is available in a small $4mm \times 4mm$ QFN package as well as a 28-lead SSOP. **LT**

Single-Wire Camera LED Charge Pump Allows Multiple Output Current Levels With Single-Resistor Programmability

by Mohammed H. Jafri

Introduction

The number of features in cell phones continues to grow, even as the phones themselves physically shrink, driving a need for space saving circuits to control these features. The LTC3218 is such a device. It can drive a white LED with multiple current levels, requiring only three 0603 ceramic capacitors and one 0402 resistor. Its low profile, 3mm x 2mm, DFN package allows for an application circuit footprint of less than 30mm², making it an ideal driver for a cell phone camera flash. Additionally, due to its single-wire, high side current sensing design, only one high current trace is required to run to the anode of the LED. The cathode of the LED can be grounded locally, eliminating the need for a separate return trace. The LTC3218 can operate from a single-cell Li-Ion battery, with an input voltage range of 2.9V to 4.5V.

The LTC3218 generates the regulated output voltage needed to maintain the desired LED current. By remaining in the current regulated, 1x mode for as much of the battery voltage range as possible, efficiency is maximized. The LTC3218 steps up to 2x mode only when needed. Figure 1 shows the efficiency of the LTC3218 for various current levels.

To protect the LED from experiencing high currents for long periods of

time, the LTC3218 features a built-in timer. This timer shuts down the part if it has been enabled in flash-mode (ENF = HIGH) for more than 2 seconds. The timer is reset by bringing the part into shutdown and re-enabling it.

Multiple Current Ratios

LED drivers often use external resistors to program LED current. The LED current is related to the programming resistor current through a fixed ratio. By employing multiple current ratios, the LTC3218 can be programmed for

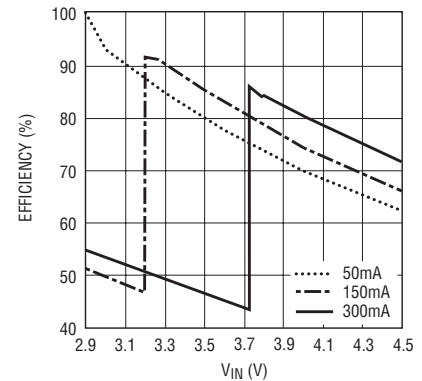

Figure 1. Efficiency vs V_{IN} for various LED currents

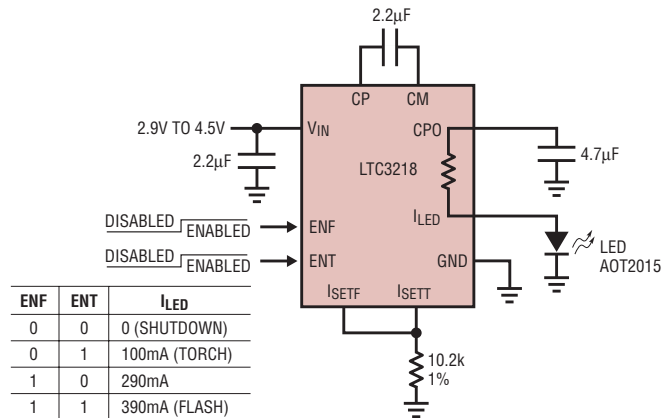

Figure 2. Typical application, using a single resistor to program LED currents

Table 1. Output current modes for all ENT and ENF settings

ENF	ENT	I_{LED}
LOW	LOW	SHUTDOWN
LOW	HIGH	$1029/R_{SETT}$
HIGH	LOW	$2965/R_{SETF}$
HIGH	HIGH	$3993/R_{SETF}$

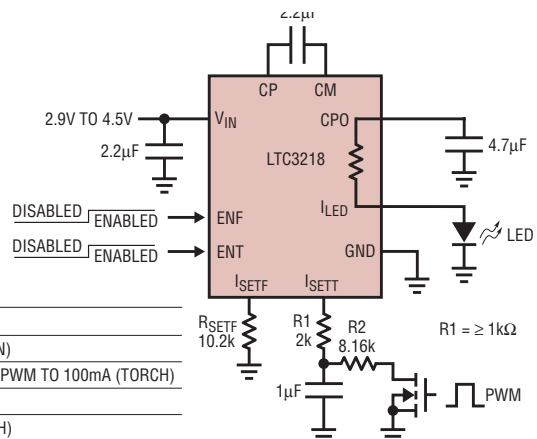

Figure 3. LED driver uses pulse-width modulation to implement dimming and brightness control

three different current levels using a single programming resistor. The current ratios are selected using the ENT and ENF pins. Table 1 shows the three different current ratios, and the ENT/ENF settings required to select them. R_{SETT} refers to the resistor connected between the I_{SETT} pin and GND, and R_{SETF} refers to the resistor connected between the I_{SETF} pin and GND. In the case where single-resistor programming is desired, the I_{SETT} and I_{SETF} pins can be shorted together and connected to a resistor to GND. Figure 2 shows an example of this configuration, along with the resulting output current levels.

Dimming and Brightness Control

Figure 3 shows how the LTC3218 can be configured to control LED brightness with just a few external components. By pulse-width modulating the gate of M1, the reference current in resistor R1 can be varied. The maximum LED current is determined by:

$$I_{LED(MAX)} = \frac{850 \cdot 1.21V}{R_{SETT}}$$

where $R_{SETT} = R1 + R2$ and the on-resistance of M1 is small compared to R_{SETT} . Resistor R1 should be greater than 1kΩ to provide adequate isola-

tion between the 1μF capacitor and the internal servo-amplifier.

Conclusion

Due to its small size and low external parts count, the LTC3218 is ideally suited for compact, camera LED applications. Features such as its single resistor programmability, multiple current ratios and 2-second flash timeout make the part simple to use, without the need for complicated control algorithms. Its low shutdown current and high efficiency make it perfect for situations where battery power is at a premium.

LT3498, continued from page 24
turned on when the part is enabled. When the part is in shutdown, the PMOS switch turns off, allowing the V_{OUT2} node to go to ground. This type of disconnect function is often required for OLED applications.

Li-Ion Powered Driver for Four White LEDs and OLED display

Figure 9 highlights the LT3498's simplicity and versatility. From a single 3mm × 2mm DFN, this circuit is ca-

pable of driving four LEDs in series, with 20mA of constant current as well as an OLED display. The efficiency for the LED driver in Figure 9 is shown in Figure 10. As shown above in Figure 1, the circuit can operate from a single Li-Ion battery (down to 3V) or 5V wall adapter and drive up to six LEDs in series at 20mA and an OLED display at 16V, 24mA out.

Conclusion

The LT3498 is a dual output boost converter that is capable of driving

up to 6 white LEDs and an OLED display from a single-cell Li-Ion input. The device features 32V internal power switches, 32V internal Schottky diodes, independent DC or PWM dimming control, open LED protection, OLED output disconnect and internal compensation. The LT3498 offers a highly integrated, space-saving solution for a wide range of applications including space-constrained and noise-sensitive portable applications such as cellular phones, MP3 players and digital cameras.

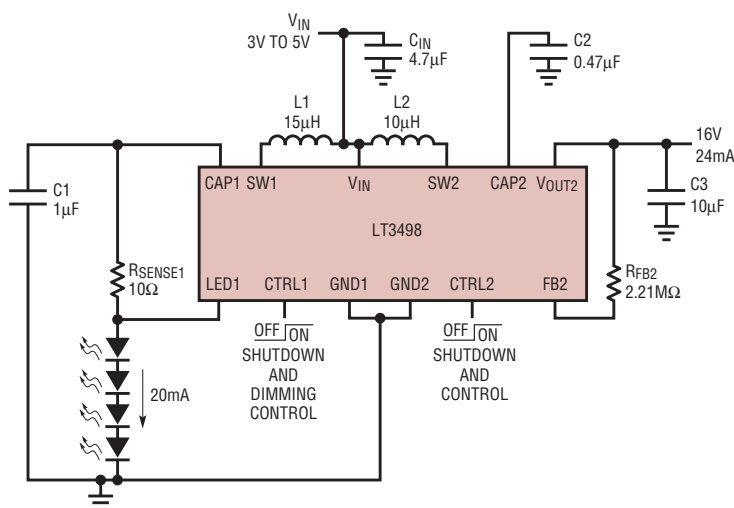

C_{IN}, C₂: X5R OR X7R WITH SUFFICIENT VOLTAGE RATING
C₁: TAIYO YUDEN GMK212BJ105KG
C₃: TAIYO YUDEN TMK316BJ106ML
L₁: MURATA LQH32CN150K53
L₂: MURATA LQH32CN100K53

Figure 9. Li-Ion to four white LEDs and an OLED display

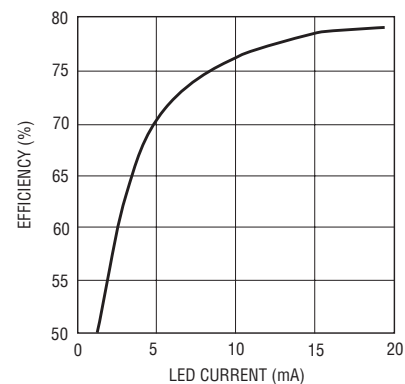

Figure 10. Efficiency of the LED driver in Figure 9

Compact Controller is a Basic Building Block for Wide Array of DC/DC Conversion Solutions

by Victor Khasiev and Hong Ren

Introduction

The LTC3873 is a compact PWM controller that can be used in boost, flyback and SEPIC DC/DC converters. Other features include:

- ❑ Wide input range, suitable for telecom and industrial applications

- ❑ No R_{SENSE}^{TM} eliminates the need for current-sensing resistor.
- ❑ Programmable soft-start
- ❑ Adjustable current limit enables a wide range of power MOSFETs
- ❑ Pulse-skipping mode maintains constant frequency operation at light loads.
- ❑ Extremely small packages: 2.8mm × 2.9mm 8-lead SOT-23 or 3mm × 2mm QFN.

One of interesting features of this IC is its programmable current limit. The current sense voltage can be set to 290mV, 110mV or 185mV. This feature allows flexibility in MOSFET selection. If a higher sensing threshold is selected, the circuit is less sensitive to noise and PCB layout.

Applications

48V Input, 3.3V, 3A Output Flyback

Figure 1 shows a nonisolated step-down converter for telecom and industrial applications with a 36V to 72V input range and a 3.3V, 3A output, impressive for such a compact converter. Efficiency is over 85%, resulting in low power loss.

48V Input, 3.3V, 3A Output Isolated Flyback

Figure 3 shows an isolated application. In this case, feedback is provided by the LT4430 optocoupler driver, which controls the PWM via I_{TH} pin of LTC3873.

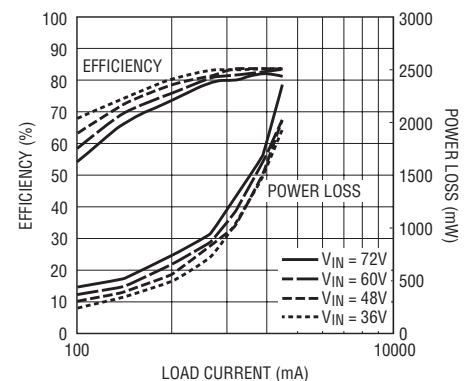

Figure 2. Efficiency of the converter in Figure 1 peaks at 86%.

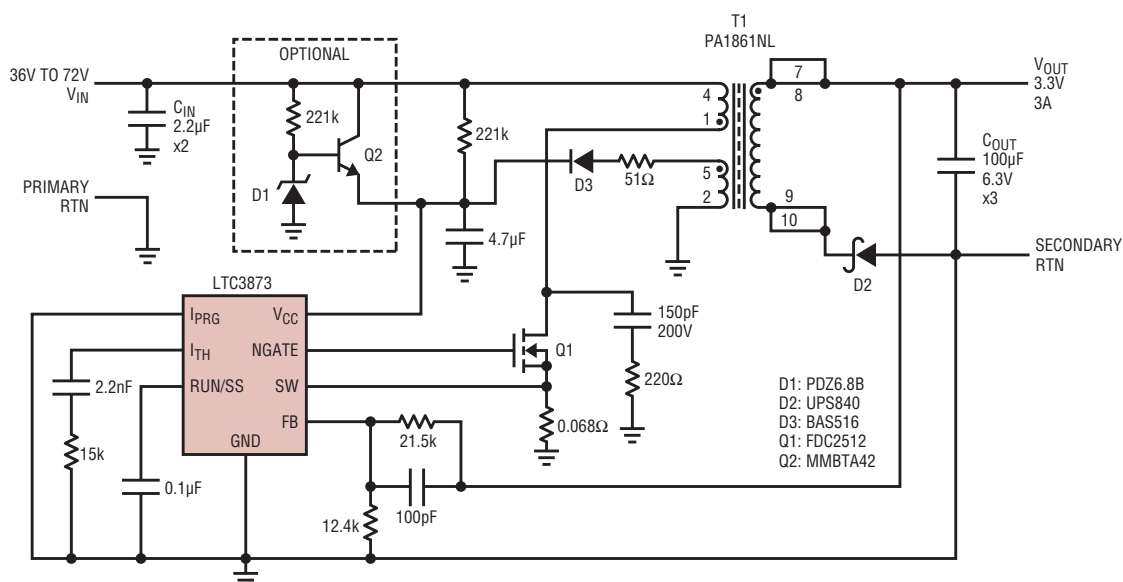

Figure 1. A nonisolated flyback converter

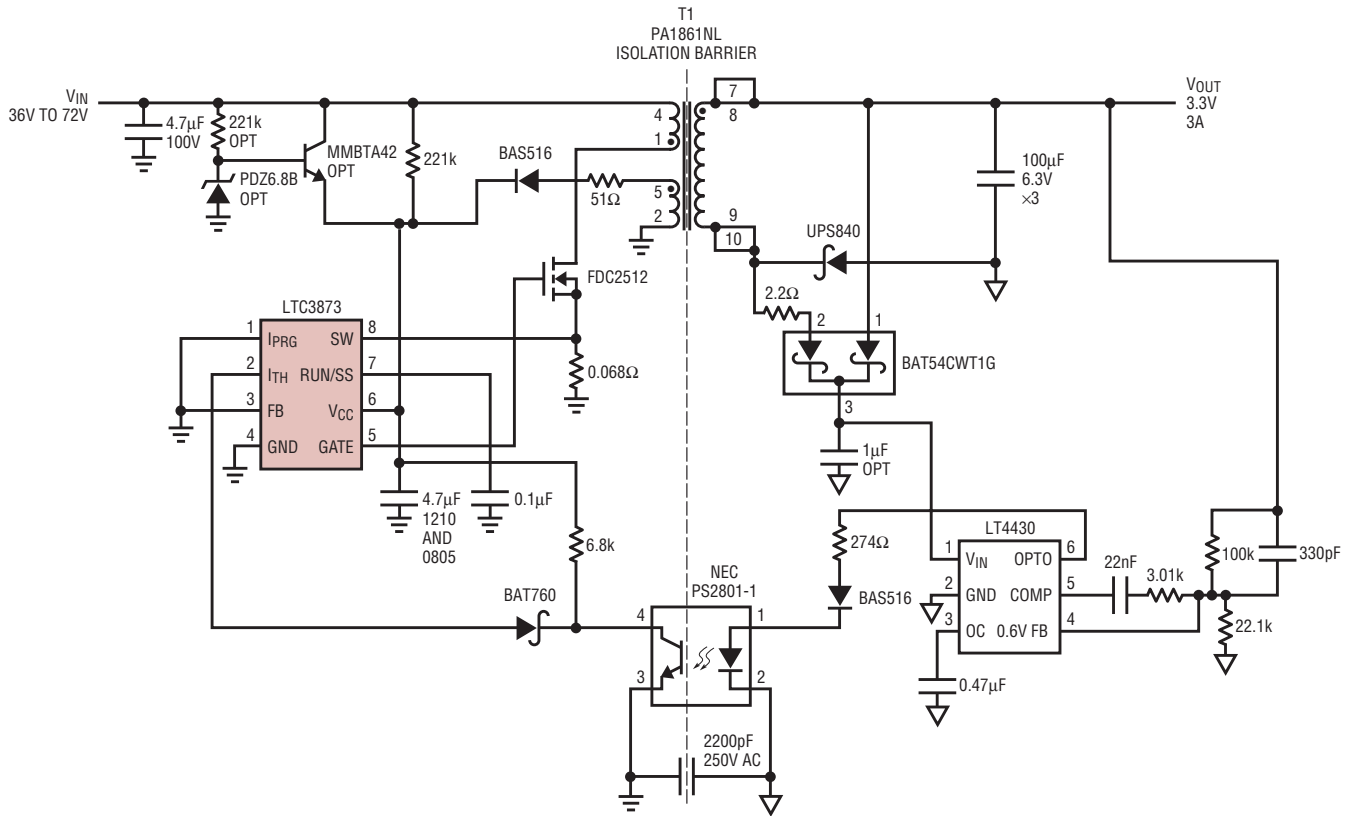

Figure 3. Isolated converter can be controlled by the LT4430 optoisolator driver, which also provides soft-start and overshoot control.

**9V-15V Input,
12V, 2A Output SEPIC**

Figure 4 shows a SEPIC that converts input voltages that can be higher or lower than the output. The advantage of a SEPIC over a flyback converter is in the higher efficiency and lower EMI.

A SEPIC converter does not provide isolation.

Adjustable Current Limit

One of interesting features of this IC is programmable current limit. The current sense voltage can be set to

290mV, 110mV or 185mV by tying the IPRG pin to V_{IN} , tying the IPRG pin to GND or leaving it floating, respectively. This feature allows flexibility in MOSFET selection. If a higher sensing threshold is selected, the circuit is less sensitive to noise and PCB layout. Keep in mind that a higher sense voltage results in higher power dissipation in the MOSFET.

Conclusion

The LTC3873 is a constant frequency, current mode controller. It requires no sense resistor and can be used in a wide variety of applications as a boost, flyback and SEPIC converter.

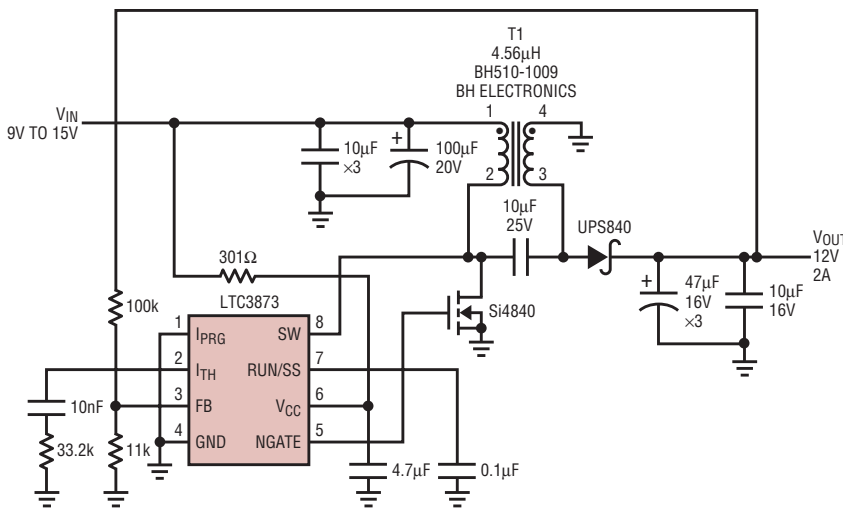

Figure 4. A SEPIC converter for applications with higher power levels and input voltages that can be higher or lower than the output voltage

Want to know more?
Visit:
www.linear.com
or call
1-800-4-LINEAR

New Device Cameos

DC/DC Converter with Selectable Frequency Modes in a 2mm × 3mm DFN

The LTC3543 is a high efficiency 600mA monolithic step-down switching regulator intended for low power applications such as Lithium-Ion battery powered devices. It operates within a 2.5V to 5.5V input voltage range and has three different frequency modes of operation.

Efficiency is extremely important in battery powered applications, and the LTC3543 keeps efficiency high with an automatic, power saving Burst Mode operation, which reduces gate charge losses at low load currents. With no load, the converter draws only 45 μ A, and in shutdown, the device draws less than 1 μ A, making it ideal for low current applications.

Burst Mode operation is an efficient solution for low current applications, but sometimes noise suppression is a higher priority. To reduce noise problems, a pulse skipping mode is available, which decreases the ripple noise at low currents. Although not as efficient as Burst Mode operation at low currents, pulse skipping mode still provides high efficiency for moderate loads. In dropout, the internal P-channel MOSFET switch is turned on continuously, thereby maximizing the usable battery life.

The LTC3543 offers three different frequency modes: fixed frequency, spread spectrum, or synchronous. In fixed frequency mode, the regulator operates at a constant 2.25MHz, making it possible to use capacitors and inductors that are less than 1.2mm in height. In spread spectrum mode, the switching frequency is randomly varied from 2MHz to 3MHz. By spreading the switcher's operating frequency, a significant reduction in peak radiated and conducting noise can be realized. In synchronous mode, the LTC3543's switching frequency can be synchronized to a 1MHz to 3MHz external clock.

The small size, efficiency, low external component count, and design

flexibility of the LTC3543 make it an ideal DC/DC converter for portable devices using a Lithium-Ion battery.

Easy-to-Use, Ultra-Tiny 16-Bit $\Delta\Sigma$ ADC

The LTC2450 is an ultra-tiny 16-bit analog-to-digital converter. It uses a single 2.7V to 5.5V supply, accepts a single-ended analog input voltage, and communicates through an SPI interface. It also includes an integrated oscillator that does not require any external components.

A delta-sigma modulator serves as a converter core and provides single-cycle settling time for multiplexed applications.

The converter is available in a 6-pin, 2mm × 2mm DFN package. The LTC2450 includes a proprietary input sampling scheme that reduces the average input sampling current by several orders of magnitude. The LTC2450 is capable of up to 30 conversions per second and, due to the very large oversampling ratio, has extremely relaxed anti-aliasing requirements.

The LTC2450 includes continuous internal offset and full-scale calibration algorithms, which are transparent to the user, ensuring accuracy over time and over the operating temperature range. The converter uses its power supply voltage as the reference voltage and the single-ended, rail-to-rail input voltage range extends from GND to V_{CC} . Following a conversion, the LTC2450 can automatically enter sleep mode and reduce its power to less than 200nA. If the user samples the ADC once a second, the LTC2450 consumes an average of less than 50 μ W from a 2.7V supply.

1.1A Low Noise LDO Offers High Power Density

The LT1965 is a low noise, low voltage 1.1A LDO with high power density. The LT1965 features a low dropout voltage of only 300mV at full load, with wide V_{IN} capability of 1.8V to 20V and low adjustable output from 1.2V to 19.5V. Ultra-low output noise of only 40 μ V_{RMS}

reduces noise in instrumentation, RF, DSP and logic supply systems and is beneficial for post-regulating switching power supplies. Output tolerance is tightly regulated to within $\pm 3\%$ over line, load and temperature. The device's low quiescent current of 500 μ A (operating) and less than 1 μ A (shutdown) make it an excellent choice for applications requiring high output drive capability with low current consumption.

The LT1965 regulator optimizes stability and transient response with low ESR, ceramic output capacitors as small as 10 μ F. These tiny external capacitors can be used without any necessary series resistance as is common with many other regulators. Internal protection circuitry includes reverse-battery protection, no reverse current, current limiting with foldback, and thermal limiting.

For applications requiring large input-to-output differentials, the LT1965 offers a very compact and thermally effective solution. The IC features a wide breadth of packaging options, ranging from modern high power density, small footprint, thermally efficient DFN and MSOPE packages to more traditional DD-Pak and TO-220 power packaging.

Powerful Family of Synchronous N-Channel MOSFET Drivers Boosts the Efficiency and Voltage Range of DC/DC Converters

The LTC4442, LTC4443, LTC4444, LTC4445, and LTC4447 family of synchronous N-channel MOSFET drivers maximizes DC/DC converter efficiency with peak output currents as high as 5A, propagation delays as low as 14ns, and high voltage operation up to 100V. From buck to boost to buck-boost, these drivers can improve the efficiency and extend the operating voltage range of a wide variety of converter topologies.

The LTC4442 features powerful 5A drivers capable of producing 5ns–12ns transition times on 3nF loads. These

rapid transition times substantially reduce the power loss in a DC/DC converter by minimizing the switching losses in MOSFETs with high gate capacitance. Adaptive shoot-through protection circuitry is also integrated to prevent power loss due to MOSFET cross-conduction current. In addition, the LTC4442 includes undervoltage lockout detectors that monitor the gate drive supply and disable operation if the voltage is too low. The LTC4442 operates with a 6V to 9.5V gate drive supply, and its floating high side driver is capable of handling 38V supply voltages.

The LTC4443 includes all of the features of the LTC4442, but also integrates the Schottky diode required for the high side bootstrapped supply to simplify layout and reduce parts count. The LTC4445 is a dual version of the LTC4443, with two independent

channels that are ideal for two-phase or 2-channel applications.

For lower gate drive supply applications, the LTC4447's rail-to-rail outputs are optimized to source 4A and sink 5A of current while operating from a 4V to 6.5V supply. With 14ns propagation delays and 5ns transition times driving 3nF loads, this high speed driver minimizes power loss due to switching losses and synchronous MOSFET body diode conduction. The low forward drop Schottky diode required for the high side bootstrapped supply is also integrated to simplify converter design and reduce board area. Like the LTC4442, the LTC4447's high side driver handles voltages up to 38V.

The LTC4444 is a powerful synchronous N-channel MOSFET driver that has been optimized for higher voltage applications. With its two CMOS-

compatible inputs connected to the Top Gate and Bottom Gate pins of a controller IC, the LTC4444 instantly extends the voltage range of a DC/DC converter to 100V. Its powerful 3A pull-up and 0.8Ω pull-down output drivers generate 10ns rise times and 5ns fall times on 1nF capacitive loads from a 7V to 14V driver supply. Adaptive shoot-through prevention and undervoltage lockout detectors are integrated to guarantee that the system is efficient and well-controlled.

The LTC4442 and LTC4444 gate drivers are available in the thermally-enhanced MSOP package, and the LTC4443, LTC4445, and LTC4447 are available in DFN packages. This family of rugged and powerful gate drivers is available in the 40°C to 85°C industrial temperature range. **LT**

LTC2953, continued from page 19

Using the reset comparator and 200ms after V1 reaches 80% of its final value (2.66V), the V2 supply is enabled. When the V2 DC voltage reaches 80% of its final value (2V), the V3 supply is enabled.

A user initiates a power down supply sequence by again pressing the pushbutton for 32ms. When \overline{EN} is released and pulls up to V_{IN} , V1 disconnects first. When the V1 supply decays to 2.66V, V2 is immediately disabled (there is no delay from VM

to \overline{RST} during power down supply sequencing). When V2 decays to 2V, V3 is immediately disabled (see the timing diagram in Figure 8).

LTC2953-1 and LTC2953-2 Versions

The LTC2953-1(EN) and LTC2953-2(\overline{EN}) differ only by the polarity of the EN/ \overline{EN} pin. The LTC2953-1 is intended to drive a DC/DC converter while the LTC2953-2 drives an external power PFET.

Pushbutton Product Family

Table 1 summarizes Linear Technology's family of pushbutton products. The LTC2950, LTC2951 and LTC2954 provide a complete standalone solution for interfacing a manual on/off pushbutton to system power and system logic. The LTC2953 adds voltage monitoring functions to allow for failsafe operation. The LTC2952 offers selectable dual power path ideal diode controllers.

Conclusion

The LTC2953 is a low power, wide input voltage range (2.7V to 27V) pushbutton on/off controller with input and output voltage monitoring. The LTC2953 provides a simple and complete solution to manually toggling power to many types of systems. It includes a power fail comparator that issues an early warning of a decaying supply, along with a UVLO comparator that prevents a user from turning on a system with a low supply or dead battery. The LTC2953 furthers system reliability by integrating an adjustable single supply supervisor. The device is available in a space saving 3mm x 3mm DFN package. **LT**

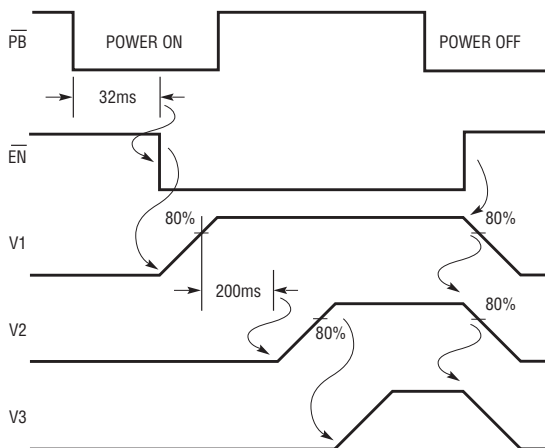

Figure 8. Timing diagrams for sequencing three supplies

www.linear.com

MyLinear

(www.linear.com/mylinear)

MyLinear is a customizable home page to store your favorite LTC products, categories, product tables, contact information, preferences and more. Creating a MyLinear account allows you to...

- Store and update your contact information. No more reentering your address every time you request a sample!
- Edit your subscriptions to *Linear Insider* email newsletter and *Linear Technology Magazine*.
- Store your favorite products and categories for future reference.
- Store your favorite parametric table. Customize a table by editing columns, filters and sort criteria and store your settings for future use.
- View your sample history and delivery status.

Using your MyLinear account is easy. Just visit www.linear.com/mylinear to create your account.

Purchase Products

(www.linear.com/purchase)

Purchase products directly from Linear Technology either through the methods below or contact your local LTC sales representative or licensed distributor.

Credit Card Purchase — Your Linear Technology parts can be shipped almost anywhere in the world with your credit card purchase. Orders up to 500 pieces per item are accepted. You can call (408) 433-5723 or email orders@linear.com with questions regarding your order.

Linear Express — Purchase online with credit terms. Linear Express is your new choice for purchasing any quantity of Linear Technology parts. Credit terms are available for qualifying accounts. Minimum order is only \$250.00. Call 1-866-546-3271 or email us at express@linear.com.

Product and Applications Information

At www.linear.com you will find our complete collection of product and applications information available for download. Resources include:

Data Sheets — Complete product specifications, applications information and design tips

Application Notes — In depth collection of solutions, theory and design tips for a general application area

Design Notes — Solution-specific design ideas and circuit tips

LT Chronicle — A monthly look at LTC products for specific end-markets

Product Press Releases — New products are announced constantly

Solutions Brochures — Complete solutions for automotive electronics, high speed ADCs, LED drivers, wireless infrastructure, industrial signal chain, handheld, battery charging, and communications and industrial DC/DC conversion applications.

Product Selection

The focus of Linear Technology's website is simple—to get you the information you need quickly and easily. With that goal in mind, we offer several methods of finding the product and applications information you need.

Part Number and Keyword Search — Search Linear Technology's entire library of data sheets, Application Notes and Design Notes for a specific part number or keyword.

Sortable Parametric Tables — Any of Linear Technology's product families can be viewed in table form, allowing the parts to be sorted and filtered by one or many functional parameters.

Applications Solutions — View block diagrams for a wide variety of automotive, communications, industrial and military applications. Click on a functional block to generate a complete list of Linear Technology's product offerings for that function.

Design Support

Packaging (www.linear.com/packaging) — Visit our packaging page to view complete information for all of Linear Technology's package types. Resources include package dimensions and footprints, package cross reference, top markings, material declarations, assembly procedures and more.

Quality and Reliability (www.linear.com/quality) — The cornerstone of Linear Technology's Quality, Reliability & Service (QRS) Program is to achieve 100% customer satisfaction by producing the most technically advanced product with the best quality, on-time delivery and service. Visit our quality and reliability page to view complete reliability data for all of LTC's products and processes. Also available is complete documentation on assembly and manufacturing flows, quality and environmental certifications, test standards and documentation and failure analysis policies and procedures.

Lead Free (www.linear.com/leadfree) — A complete resource for Linear Technology's Lead (Pb) Free Program and RoHS compliance information.

Simulation and Software

Linear Technology offers several powerful simulation tools to aid engineers in designing, testing and troubleshooting their high performance analog designs.

LTspice/SwitcherCAD™ III (www.linear.com/swcad) — LTspice / SwitcherCAD III is a powerful SPICE simulator and schematic capture tool specifically designed to speed up and simplify the simulation of switching regulators. LTspice / SwitcherCAD III includes:

- Powerful SPICE simulator specifically designed for switching regulator simulation
- Complete and easy to use schematic capture and waveform viewer
- Macromodels for most of Linear Technology's switching regulators as well as models for many of LTC's high performance linear regulators, op amps, comparators, filters and more.
- Ready to use demonstration circuits for over one hundred of Linear Technology's most popular products.

FilterCAD — FilterCAD 3.0 is a computer-aided design program for creating filters with Linear Technology's filter ICs.

Noise Program — This program allows the user to calculate circuit noise using LTC op amps and determine the best LTC op amp for a low noise application.

SPICE Macromodel Library — A library includes LTC op amp SPICE macromodels for use with any SPICE simulation package.

SALES OFFICES

NORTH AMERICA

GREATER BAY AREA

Bay Area
720 Sycamore Dr.
Milpitas, CA 95035
Phone: (408) 428-2050
FAX: (408) 432-6331

Sacramento

2260 Douglas Blvd., Ste. 280
Roseville, CA 95661
Tel: (916) 787-5210
Fax: (916) 787-0110

PACIFIC NORTHWEST

Denver
7007 Winchester Cir., Ste. 130
Boulder, CO 80301
Tel: (303) 926-0002
Fax: (303) 530-1477

Portland

5005 SW Meadows Rd., Ste. 410
Lake Oswego, OR 97035
Phone: (503) 520-9930
FAX: (503) 520-9929

Salt Lake City

Phone: (801) 731-8008

Seattle

2018 156th Ave. NE, Ste. 100
Bellevue, WA 98007
Phone: (425) 748-5010
FAX: (425) 748-5009

SOUTHWEST

Los Angeles
21243 Ventura Blvd., Ste. 238
Woodland Hills, CA 91364
Phone: (818) 703-0835
FAX: (818) 703-0517

Orange County

15375 Barranca Pkwy., Ste. A-213
Irvine, CA 92618
Phone: (949) 453-4650
FAX: (949) 453-4765

San Diego

5090 Shoreham Place, Ste. 110
San Diego, CA 92122
Phone: (858) 638-7131
FAX: (858) 638-7231

CENTRAL

Chicago
2040 E. Algonquin Rd., Ste. 512
Schaumburg, IL 60173
Phone: (847) 925-0860
FAX: (847) 925-0878

Cleveland

7550 Lucerne Dr., Ste. 106
Middleburg Heights, OH 44130
Phone: (440) 239-0817
FAX: (440) 239-1466

Columbus

Phone: (614) 488-4466

Detroit

39111 West Six Mile Road
Livonia, MI 48152
Phone: (734) 779-1657
Fax: (734) 779-1658

Indiana

Phone: (317) 581-9055

Kansas

Phone: (913) 829-8844

Minneapolis

7805 Telegraph Rd., Ste. 225
Bloomington, MN 55438
Phone: (952) 903-0605
FAX: (952) 903-0640

Wisconsin

Phone: (262) 859-1900

NORTHEAST

Boston

15 Research Place
North Chelmsford, MA 01863
Phone: (978) 656-4750
FAX: (978) 656-4760

Connecticut

Phone: (860) 228-4104

Philadelphia

3220 Tillman Dr., Ste. 120
Bensalem, PA 19020
Phone: (215) 638-9667
FAX: (215) 638-9764

SOUTHEAST

Atlanta

Phone: (770) 888-8137

Austin

8500 N. Mopac, Ste. 603
Austin, TX 78759
Phone: (512) 795-8000
FAX: (512) 795-0491

Dallas

17000 Dallas Pkwy., Ste. 200
Dallas, TX 75248
Phone: (972) 733-3071
FAX: (972) 380-5138

Fort Lauderdale

Phone: (954) 473-1212

Houston

1080 W. Sam Houston Pkwy., Ste. 225
Houston, TX 77043
Phone: (713) 463-5001
FAX: (713) 463-5009

Huntsville

Phone: (256) 881-9850

Orlando

Phone: (407) 688-7616

Raleigh

15100 Weston Pkwy., Ste. 202
Cary, NC 27513
Phone: (919) 677-0066
FAX: (919) 678-0041

Tampa

Phone: (813) 634-9434

ASIA

CHINA

Linear Technology Corp. Ltd.
Units 1503-04, Metroplaza Tower 2
223 Hing Fong Road
Kwai Fong, N.T., Hong Kong
Phone: +852 2428-0303
FAX: +852 2348-0885

Linear Technology Corp. Ltd.

Room 902, Evergo Tower
1325 Huaihai M. Road
Shanghai, 200031, PRC
Phone: +86 (21) 6375-9478
FAX: +86 (21) 5465-5918

Linear Technology Corp. Ltd.

Room 816, 8/F
China Electronics Plaza B
No. 3 Dan Ling Rd., Hai Dian District
Beijing, 100080, PRC
Phone: +86 (10) 6801-1080
FAX: +86 (10) 6805-4030

Linear Technology Corp. Ltd.

Room 2604, 26/F
Excellence Times Square Building
4068 YiTian Road, Futian District
Shenzhen, 518048, PRC
Phone: +86 755-8236-6088
FAX: +86 755-8236-6008

JAPAN

Linear Technology KK
8F Shuwa Kioicho Park Bldg.
3-6 Kioicho Chiyoda-ku
Tokyo, 102-0094, Japan
Phone: +81 (3) 5226-7291
FAX: +81 (3) 5226-0268

Linear Technology KK

6F Kearny Place Honmachi Bldg.
1-6-13 Awaza, Nishi-ku
Osaka-shi, 550-0011, Japan
Phone: +81 (6) 6533-5880
FAX: +81 (6) 6543-2588

Linear Technology KK

7F, Sakuradori Ohtsu KT Bldg.
3-20-22 Marunouchi, Naka-ku
Nagoya-shi, 460-0002, Japan
Phone: +81 (52) 955-0056
FAX: +81 (52) 955-0058

KOREA

Linear Technology Korea Co., Ltd.

Yundang Building, #1002
Samsung-Dong 144-23
Kangnam-Ku, Seoul 135-090
Korea
Phone: +82 (2) 792-1617
FAX: +82 (2) 792-1619

SINGAPORE

Linear Technology Pte. Ltd.

507 Yishun Industrial Park A
Singapore 768734
Phone: +65 6753-2692
FAX: +65 6752-0108

TAIWAN

Linear Technology Corporation

8F-1, 77, Nanking E. Rd., Sec. 3
Taipei, Taiwan
Phone: +886 (2) 2505-2622
FAX: +886 (2) 2516-0702

EUROPE

FINLAND

Linear Technology AB
Teknobulevardi 3-5
P.O. Box 35
FIN-01531 Vantaa
Finland
Phone: +358 (0)9 2517 8200
FAX: +358 (0)9 2517 8201

FRANCE

Linear Technology S.A.R.L.
Parc Tertiaire Silic
2 Rue de la Couture, BP10217
94518 Rungis Cedex
France
Phone: +33 (1) 56 70 19 90
FAX: +33 (1) 56 70 19 94

GERMANY

Linear Technology GmbH
Osterfeldstrasse 84, Haus C
D-85737 Ismaning
Germany
Phone: +49 (89) 962455-0
FAX: +49 (89) 963147

Linear Technology GmbH

Haselburger Damm 4
D-59387 Ascheberg
Germany
Phone: +49 (2593) 9516-0
FAX: +49 (2593) 951679

Linear Technology GmbH

Jesinger Strasse 65
D-73230 Kirchheim/Teck
Germany
Phone: +49 (0)7021 80770
FAX: +49 (0)7021 807720

ITALY

Linear Technology Italy Srl

Orione 3, C.D. Colleoni
Via Colleoni, 17
I-20041 Agrate Brianza (MI)
Italy
Phone: +39 039 596 5080
FAX: +39 039 596 5090

SWEDEN

Linear Technology AB

Electrum 204
Isafjordsgatan 22
SE-164 40 Kista
Sweden
Phone: +46 (8) 623 16 00
FAX: +46 (8) 623 16 50

UNITED KINGDOM

Linear Technology (UK) Ltd.

3 The Listons, Liston Road
Marlow, Buckinghamshire SL7 1FD
United Kingdom
Phone: +44 (1628) 477066
FAX: +44 (1628) 478153

Linear Technology Corporation

1630 McCarthy Blvd.
Milpitas, CA 95035-7417
TEL: (408) 432-1900
FAX: (408) 434-0507
www.linear.com

